

Flex Spectrum Exterior

CONTENTS

INTRODUCTION	2
Welcome	2
Safety, maintenance and cleaning	2
INSTALLATION	3
Cleaning the mounting surface (for adhesive tape)	3
Cutting and connecting the tape	4
Powering and dimming Flex Spectrum tapes	5
Do not mount underneath surfaces	7
Clip mounting	7
Flex channel (FLX477)	8
FURTHER INFORMATION	10
Flex channel dimensions	10
Flex Spectrum Exterior specifications	11
Limited product warranty	12

INTRODUCTION

WELCOME

Welcome to the Flex Spectrum Exterior range from Acclaim Lighting. These high output LED tapes are designed and built with ingress protection to IP68 (submersible to 1m) to survive the elements. A range of mounting channels with UV stabilized coatings (see opposite page) and accessories are available to suit numerous installation situations.

Flex Spectrum Exterior tapes use quad color diodes with warm white, red, green and blue emitters to allow a much wider range of saturated and pastel color mixes. By mixing blue with the warm white it is possible to achieve a full range of whites ranging from 3000K to 7000K while maintaining CRI (Color Rendering Index) values in excess of 80.

Flex Spectrum Exterior tapes require a 24VDC supply and dimming is supported using Pulse Width Modulation (PWM) by various optional driver units - see page 5.

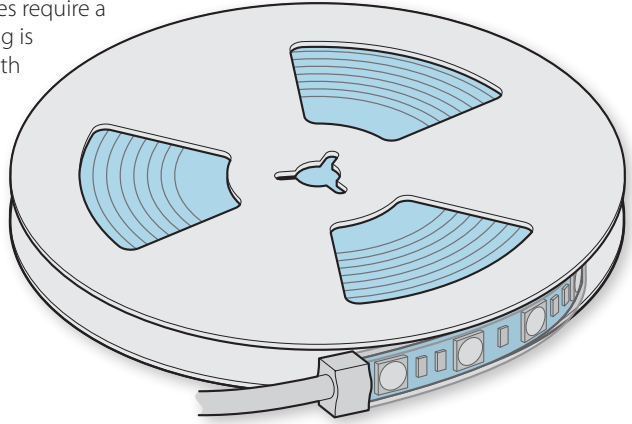

SAFETY

- When fixtures are mounted off-ground, ensure they are securely fitted to an appropriate mounting surface.
- Ensure that the power input is supplied from a correctly fused, earthed and environmentally protected location.

MAINTENANCE

CAUTION: Always isolate mains power before starting maintenance operations.

- Ensure that all mounting (and device) screws/bolts are fully tight and free of corrosion.
- Ensure there is no deformation to the housing, lenses or fixing points.
- Check that all power supply cables are free from physical damage or material fatigue.
- Use only genuine spare parts supplied by Acclaim Lighting.

CLEANING

- Use a moist, lint-free cloth when cleaning each fixture.
- Never use alcohol or solvents.

INSTALLATION

Flex Spectrum Exterior tapes are fully sealed within a flexible UV stabilized silicon tube. Mounting to surfaces is usually achieved either by using the ten silicone clips (plus screws) provided or any of the optional aluminum channels or optional adhesive tapes. The recommended aluminum channels produce an interference fit when the Flex Spectrum tape is fitted into them. We recommend you use Dow Corning® 799, 1199 (or equivalent) silicone to seal the channels against moisture ingress and also ensure all Flex Spectrum connections, within the channels, are fully encapsulated.

WHEN MOUNTING ON THE SIDES OF SURFACES

We recommend that you add small dots of silicone sealant along both sides of the Flex tape (to overlap the tape edge and mounting surface) using Dow Corning® 799, 1199 or equivalent. This will provide additional stability and help to prevent any separation of the tape from the mounting surface over time. The silicone dots are best applied once the tape is fixed in place; then the whole installation should not be disturbed until the sealant has fully cured.

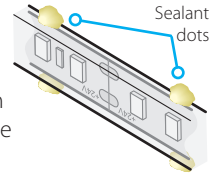

IMPORTANT: This product is not designed to be mounted underneath surfaces and should never be installed in this manner, even if housed within a channel. See page 7.

CLEANING THE MOUNTING SURFACE (FOR ADHESIVE TAPE)

Most substrates are best prepared by cleaning with a 50:50 mixture of isopropyl alcohol (IPA) and water* prior to applying the tape. Exceptions to this general procedure that may require additional surface preparation include:

HEAVY OILS

A degreaser or solvent-based cleaner* (such as 3M™ Prep Solvent 70, 3M™ Citrus Base Cleaner, mineral spirits, naphtha or similar, subject to suitability for the surface material) may be required to remove heavy oil or grease from a surface and should be followed by cleaning with IPA/water*.

OTHER CONTAMINATION OR OXIDATION

Abrading a surface, followed by cleaning with IPA/water*, can remove heavy dirt or oxidation (e.g. galvanized steel) and can increase surface area to improve adhesion. Abrasion often also helps adhesion to paints and plastics. Very small scratches in the surface, generated with circular motion rather than straight-line motion, are most desirable.

** Note: These cleaner solutions contain greater than 250 g/l of volatile organic compounds (VOC). Please consult your local Air Quality Regulations to be sure the cleaner is compliant. When using solvents, be sure to follow the manufacturer's precautions and directions for use when handling such materials.*

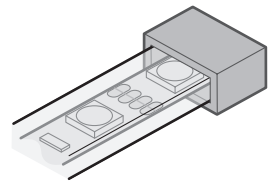

Two silicone end caps are provided with each Flex Spectrum spool to protect cut ends

CUTTING AND CONNECTING THE TAPE

Flex Spectrum tapes are supplied with ready made connections at one end. All models are supplied with a 3.28' (1m) encapsulated cable with bare ends.

TO CUT THE TAPE

Flex Spectrum tapes are marked with a cut line every four inches (100mm) - every six emitters.

IMPORTANT: Do not cut the tape at any location other than the cut line. Ensure the cut is made cleanly through the silicone outer and along the line.

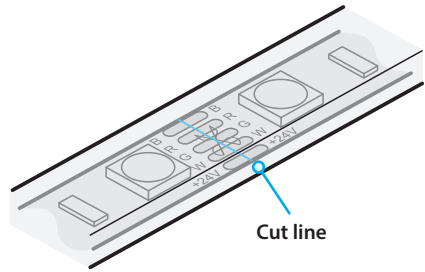

TO CONNECT THE TAPE

Once cuts are made to a Flex Spectrum tape, connections need to be made to the new sections. Either side of each cut line are bare copper contact pads where you can make connections by soldering feed wires.

1 After the tape has been cut, with great care use a sharp knife to cut away the silicone outer from around the contact pads. Remove small amounts of silicone at a time and take care not to cut into the tape.

2 Using a suitable soldering iron, solder your feed/link cables to the contact pads.

Note: When soldering, minimize the time spent heating the tape to avoid damage to the nearby components.

CONTACT PADS

Flex Spectrum tapes have five connections. The contacts are labeled at each cut line:

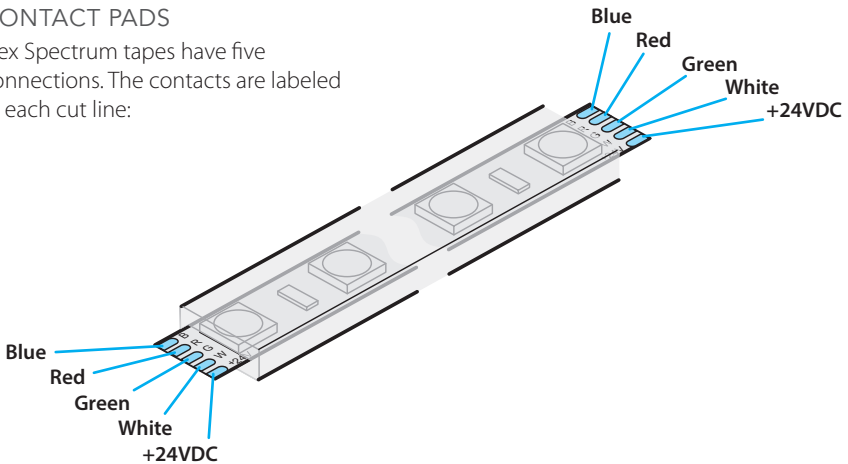

3 Use Dow Corning® 799, 1199 or equivalent silicone sealant to form a complete seal around the exposed tape, connections and cables so that water ingress is prevented. The silicone seal is best achieved once the Flex Spectrum is fixed in place, however, it can also be done prior to installation. Allow the sealant to fully set before disturbing the tape.

POWERING AND DIMMING FLEX SPECTRUM TAPES

Flex Spectrum tapes are run at 24VDC and consume power as follows:

per foot	per meter	per 16.4' (5m) spool
• 5.4W	18W	90W

Note: The maximum overall tape length per run is 16.4' (5 meters). This is limited by the current capacity of the power buses within each tape.

CONNECTION CABLES

The connection cables (not supplied) used to link Flex Spectrum tapes to the power/driver unit should follow these guidelines (based on a load of 3.13A for 16.4'/5 meters of Flex Spectrum tape):

- Up to 40 feet (12m) 18 AWG (0.823mm²)
- Up to 100 feet (30m) 14 AWG (2.081mm²)
- Up to 180 feet (54m) 12 AWG (3.309mm²)

In all cases, ensure the voltage drop at the fixture end of the link cable is no greater than 9% (2.16V) of the original 24VDC supply.

FLEX SPECTRUM POWER SUPPLIES AND DIMMERS

AL Driver 400 unit

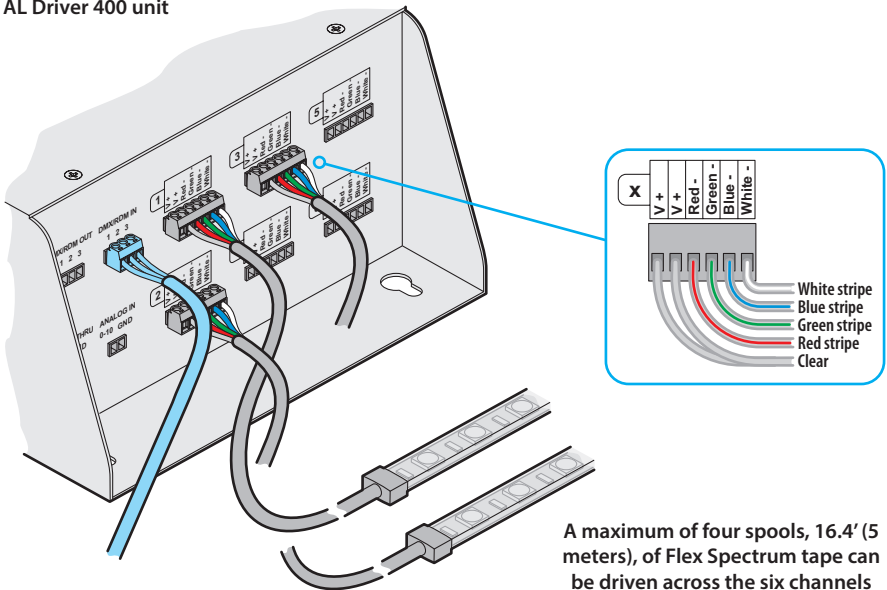

A maximum of four spools, 16.4' (5 meters), of Flex Spectrum tape can be driven across the six channels of the unit; maximum of one spool per channel.

AL Driver 800 unit

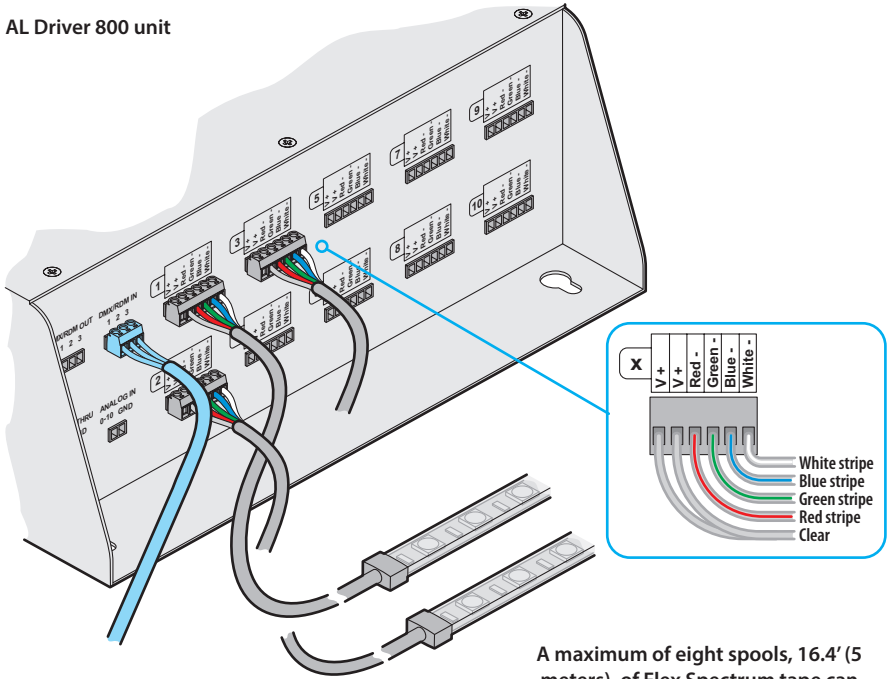

A maximum of eight spools, 16.4' (5 meters), of Flex Spectrum tape can be driven across the ten channels of the unit; maximum of one spool per channel.

DO NOT MOUNT UNDERNEATH SURFACES

IMPORTANT: This product is not designed to be mounted underneath surfaces and should never be installed in this manner, even if housed within a channel.

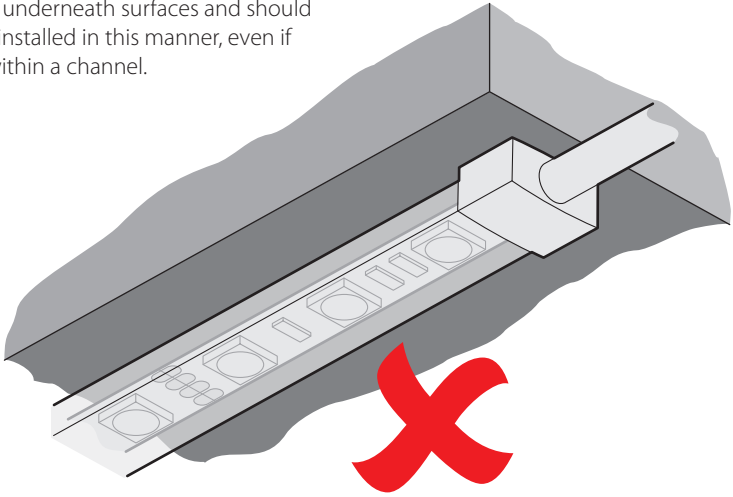

CLIP MOUNTING

Each Flex Spectrum tape spool is supplied complete with ten UV stabilized silicone mounting clips and twenty wood screws (M3 x 10mm) that can be used to directly fix the tape to appropriate surfaces.

Ensure that the supplied screws are suitable for the mounting surface, otherwise source alternative screws/bolts with diameters up to 0.12" (3mm).

Tip: When mounting the tape, take care not to place the clips over the LED emitters as light output will be affected.

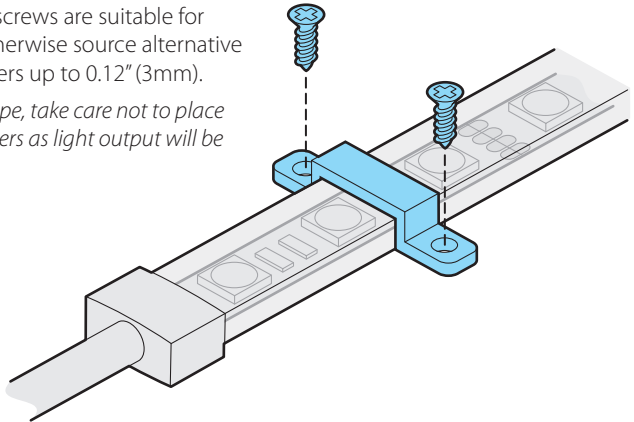

FLEX CHANNEL (FLX477)

FLX477 is a low profile option with no lens. For channel dimensions, see page 10.

Options

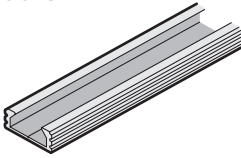

Flex channel low profile
(4' / 1.21m)
[FLX477]

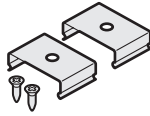

**Flat brackets/joiners
plus 2.5 x 10mm
wood screws**
[FLX111]

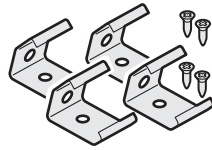

**Angled brackets plus 2.5 x
10mm wood screws**
[FLX113]

TO FIT THE FLEX SPECTRUM TAPE

IMPORTANT: This product is not designed to be mounted underneath surfaces and should never be installed in this manner, even if housed within a channel. See page 7.

- 1 If necessary, cut the channel to the required length. Remove any resulting burrs.
- 2 Ensure the tape mounting surface within the channel is completely dry and clean.
- 3 Determine the length of tape required. Mark the positions at each end of the channel where the tape will be placed.

Note: The molded Flex Spectrum connector fitted on each spool is too large to fit within the channel.

Note: Flex Spectrum tape can only be cut every 4" (100mm) and this may mean that a precise length of Flex Spectrum tape cannot be achieved. Therefore it may be beneficial to center the tape within the channel to achieve an even distribution (subject to the above note).

- 4 Cut the tape to the nearest marked cutpoint.

5 *Note: If you are attaching the channel directly to a surface, see 'To surface mount directly' on page 9 before inserting the tape.*

Carefully push the tape into the channel, starting at the marked position. The tape's size will cause an interference fit within the channel, keeping it in place without adhesive.

IMPORTANT: While pressing the Flex Spectrum tape into position, take care not to put excessive pressure on the components or connections.

- 6 If necessary, use Dow Corning® 799, 1199 or equivalent silicone sealant to fully encapsulate the power connections to protect against any moisture ingress.

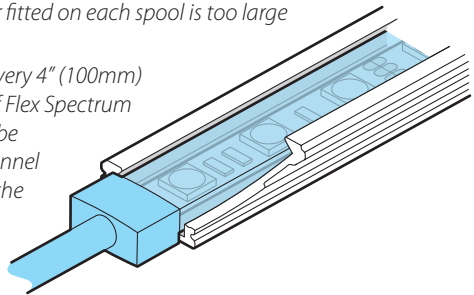

TO SURFACE MOUNT DIRECTLY

- 1 Before fitting the Flex Spectrum tape, determine where the channel is to be mounted.
- 2 Drill the required number of holes in the base of the channel and countersink them. *Note: A small groove runs down the center of each channel base to provide a guide for your drill.*
- 3 Mount the channel and use countersunk screws to secure it. **IMPORTANT: The screw heads must lie flush with the channel base.**
- 4 Fit the Flex Spectrum tape to the channel (see page 8).
- 5 Carefully solder to the contact pads, if necessary (see page 4).

Drill countersunk holes and use screws that will lie flush with the channel base

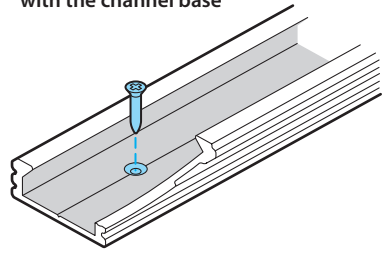

TO SURFACE MOUNT USING BRACKETS

- 1 If necessary, carefully solder to the contact pads (see page 4).
- 2 Fit the Flex Spectrum tape to the channel (see page 8).
- 3 Attach two or more brackets (of the required type: *Flat brackets* or *Angled brackets*) to the mounting surface using either the supplied screws or others that are more appropriate to the surface type.

If necessary, solder the link cables to the contact pads

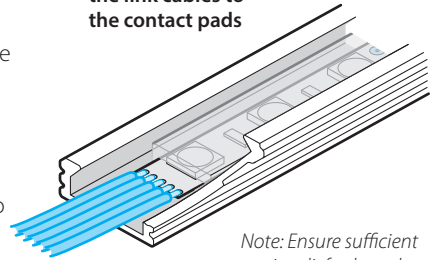

Note: Ensure sufficient strain relief where the cables enter the channel.

The angled bracket can be used in either of two orientations to provide an angle of either 30 or 45 degrees to the mounting surface (as shown below).

- 4 Clip the channel into the mounting brackets:

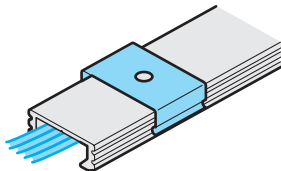

Attaching a flat bracket

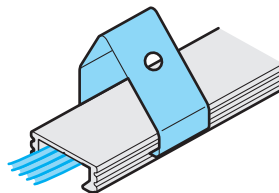

Attaching an angled bracket

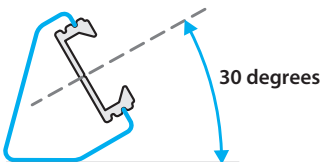

30 degrees

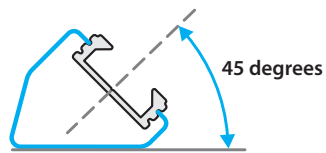

45 degrees

The angled bracket can be used in either of two orientations to provide angles of either 30 or 45 degrees to the mounting surface

FURTHER INFORMATION

FLEX CHANNEL DIMENSIONS

The FLX477 channels and lenses are supplied in lengths of 4' (1.21m).

[FLX477]

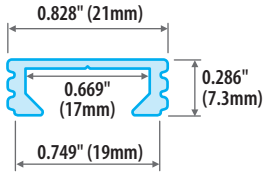

FLEX SPECTRUM EXTERIOR SPECIFICATIONS

Beam angle	120°
Color temperature (CCT)	RGB plus 3000K white emitters
Lumen maintenance (L ₇₀)	50,000 hours (25°C max)
Operating voltage	24VDC
Power consumption	5.4W per foot 18W per meter 90W per 16.4' (5m) spool
Dimming control	Pulse width modulation
Maximum overall length	16.4' (5m)
Ingress protection	IP68
Dimensions (W x H x L)	0.59" x 0.16" x 16.4' 15 x 4 x 5000mm
Operating temperature	-40°F to 122°F -40°C to 50°C
Housing	UV coated, flexible silicone jacket
Certifications	



RoHS

LIMITED PRODUCT WARRANTY

A. Acclaim Lighting™ hereby warrants, to the original purchaser, Acclaim Lighting finished products to be free of manufacturing defects in material and workmanship for a standard period of:

- Fixtures: 5 Years (1,825 days) from the date of purchase.
- Drivers, power supplies and accessories: 5 Years (1,825 days) from the date of purchase.
- Flex Products: 3 Years (1,095 days) from the date of purchase.
- Controllers: 2 Years (730 days) from the date of purchase.

It is the owner's responsibility to establish the date and place of purchase and warranty terms by acceptable evidence, at the time service is sought.

B. For warranty service, send the product only to the Acclaim factory. All shipping charges must be pre-paid. If the requested repairs or service (including parts replacement) are within the terms of this warranty, Acclaim Lighting will pay return shipping charges only to a designated point within the United States. If the entire instrument is sent, it must be shipped in its original package. No accessories should be shipped with the product. If any accessories are shipped with the product, Acclaim Lighting shall have no liability whatsoever for loss of or damage to any such accessories, nor for the safe return thereof. Acclaim reserves the right to replace the item with same or similar product at its discretion.

C. This warranty is void if the serial number has been altered or removed; if the product is modified in any manner which Acclaim concludes, after inspection, affects the reliability of the product; if the product has been repaired or serviced by anyone other than the Acclaim Lighting factory unless prior written authorization was issued to purchaser by Acclaim Lighting; if the product is damaged because not properly maintained as set forth in the instruction manual.

D. This is not a service contract, and this warranty does not include maintenance, cleaning or periodic check-up nor do we guarantee as part of this warranty any lumen performance during period. Parts not covered by this warranty include: fuses, external power supplies, third party items not manufactures by Acclaim lighting. During the period specified above, Acclaim Lighting will replace defective parts at its expense, and will absorb all expenses for warranty service and repair labor by reason of defects in material or workmanship. The sole responsibility of Acclaim Lighting under this warranty shall be limited to the repair of the product, or replacement thereof, including parts, at the sole discretion of Acclaim Lighting. At no time will installation or re-installation or products labor or liability costs will be assumed by Acclaim Lighting. All products covered by this warranty were manufactured after January 1, 2012, and bear identifying serial number marks to that effect.

E. Acclaim Lighting reserves the right to make changes in design and/or improvements upon its products without any obligation to include these changes in any products theretofore manufactured. No warranty, whether expressed or implied, is given or made with respect to any accessory supplied with products describe above. Except to the extent prohibited by applicable law, all implied warranties made by Acclaim Lighting in connection with this product, including warranties of merchantability or fitness, are limited in duration to the warranty period set forth above. And no warranties, whether expressed or implied, including warranties of merchantability or fitness, shall apply to this product after said period has expired.

F. Marine or extreme weather location applications using Acclaim lighting products are subject to a 2 year limited warranty and Acclaim must be notified prior to delivery of units for such applications so that preventative treatment can be made to the products to ensure proper performance and product life with a special marine code coating / sealing process at an additional cost.

G. The consumer's and or dealer's sole remedy shall be such repair or replacement as is expressly provide above; and under no circumstances shall Acclaim Lighting be liable for any loss or damage, direct or consequential, arising out of the use of, or inability to use, this product. This warranty is the only written warranty applicable to Acclaim Lighting products and supersedes all prior warranties and written descriptions of warranty terms and conditions heretofore published.

www.acclaimlighting.com