

## Dyna Drum SO™

**aria**™  
WIRELESS DMX

**OUTDOORLINK**   
SYSTEM



# CONTENTS

<b>INTRODUCTION .....</b>	<b>2</b>
Welcome	2
Safety, maintenance and cleaning	2
Supplied items and optional extras	3
Outdoor Linking System part codes	4
<b>INSTALLATION .....</b>	<b>5</b>
Mounting the unit	5
Using a tenon mount	6
Using a pipe clamp	7
Fitting a spread lens	8
Fitting a snoot	9
Power and control wiring	10
Wired DMX control	11
Input wiring protection	12
Cabling with OLS	13
Wireless DMX control	15
<b>CONFIGURATION .....</b>	<b>16</b>
Entering the menu	16
Setting the DMX address	18
Returning to factory settings	18
Viewing fixture information	18
Adjusting the gamma setting	19
Adjusting the PWM frequency	19
Changing the display settings	20
Setting an internal color/output	20
Running a system test	21
Setting a white balance	21
Configuring Aria wireless DMX	22
Using the automation features (Photocell)	23
Determining solo behavior	24
Configuration via RDM	25
<b>FURTHER INFORMATION .....</b>	<b>29</b>
Troubleshooting	29
Optimizing signal strength via channel selection	30
Choosing the right location	31
Specifications	32
Dimensions	33
Limited product warranty	34

# INTRODUCTION

## WELCOME

Welcome to the Dyna Drum SO range from Acclaim Lighting. These rugged LED-powered fixtures are designed to replace traditional external flood lights while using a fraction of the power. The Dyna Drum SO range consists of three main variants:

- **White** - 2700K, 3000K, 3500K, 4000K or 5700K,
- **Single Color Series** - RGBW ( $W=4000K$ ), RGBA, RGBAW ( $W=4000K$ ) or DW (2400K-5500K)\*
- **Color** - RGBW where: QS ( $W=3000K$ ), QW4 ( $W=4000K$ ) or QW6 ( $W=6000K$ )

External control using the DMX-512A is supported either through direct cable connection or via the in-built Aria™ wireless DMX receiver (*transmitter available as an optional extra*).

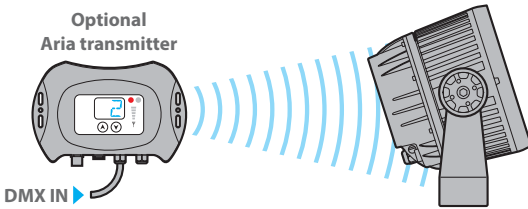

A clear daylight-readable OLED touch-screen user display provides access to a comprehensive configuration menu system (see page 16). Alternatively, the industry standard RDM (*Remote Device Management*) format can be

used to configure the DMX start address and wireless channel (see page 25).

Dyna Drum SO fixtures feature automated operation when light levels fall below a certain level together with a timer for auto shut off. The internal auto-sensing power supply can accept mains inputs between 100 to 277VAC at 50 or 60Hz. Total power consumption ranges from 135 to 150W depending on the model.

All models can be specified with Outdoor Link System connectors pre-fitted instead of bare tails. OLS greatly simplifies the task of distributing power and control to multiple fixtures (see pages 4 and 13).



*\*Single Color Series (SCS) models feature individual single-color emitters (Red, Green, Blue, White and/or Amber) which operate in unison to produce the required effect (as opposed to the Color models which use combined Chip On Board (COB) quad RGBW emitters.*

## SAFETY

- When fixtures are mounted off-ground, ensure they are securely fitted to an appropriate mounting surface.
- Ensure that the power input is supplied from a correctly fused, earthed and environmentally protected location.

## MAINTENANCE

**CAUTION: Always isolate mains power before starting maintenance operations.**

- Ensure that all mounting (and device) screws/bolts are fully tight and free of corrosion.
- Ensure there is no deformation to the housing, lenses or fixing points.
- Check that all power supply cables are free from physical damage or material fatigue.
- Use only genuine spare parts supplied by Acclaim Lighting.

## CLEANING

- Use a moist, lint-free cloth when cleaning each fixture.
- Never use alcohol or solvents.

## SUPPLIED ITEMS

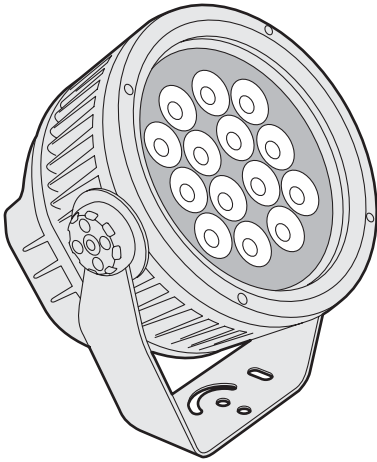

### Dyna Drum 50

Supplied with integral mounting yoke and 5 foot (1.5m) combined power and control tail.

## OPTIONAL EXTRAS

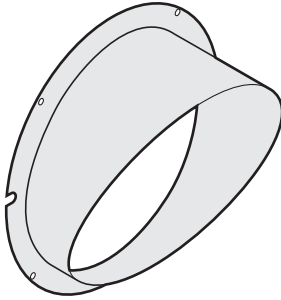

### Half snoot

Gray [DDSOHSG]

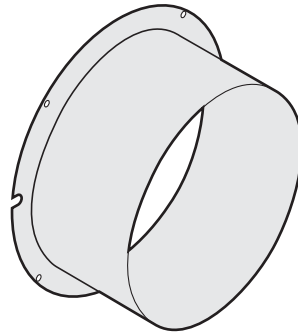

### Full snoot

Gray [DDSOFSG]

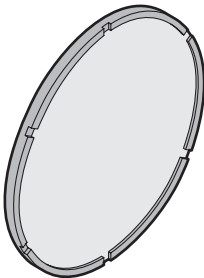

### Spread lens

20° beam [DDSSL20]  
40° beam [DDSSL40]  
60° beam [DDSSL60]  
10° x 60° beam [DDSSL1060]

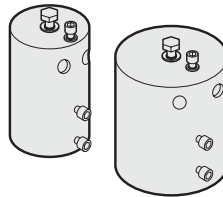

### Tenon mounts

2" pole [TM2]  
4" pole [TM4]

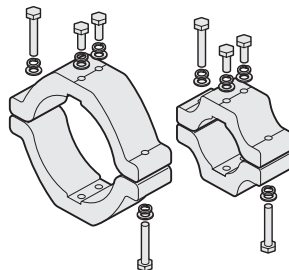

### Pipe clamps

2" pipe [PC2]  
4" pipe [PC4]

# OUTDOOR LINKING SYSTEM PART CODES

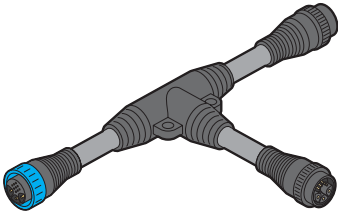

**T-junction**  
[OLST]

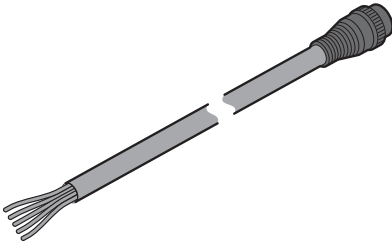

**Feed cables**  
1' (30cm) [OLSF1]  
5' (1.5m) [OLSF5]  
10' (3m) [OLSF10]  
25' (7.6m) [OLSF25]  
50' (15.2m) [OLSF50]

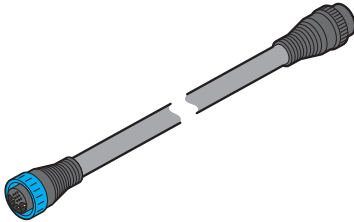

**Link cables**  
1' (30cm) [OLSL1]  
5' (1.5m) [OLSL5]  
10' (3m) [OLSL10]  
25' (7.6m) [OLSL25]  
50' (15.2m) [OLSL50]



**Terminator**  
[OLSEC]

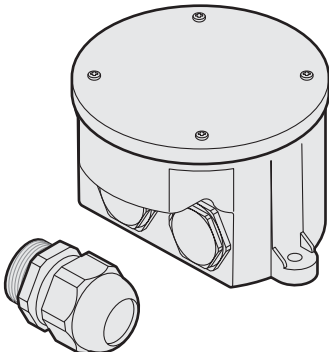

**IP66 junction box plus outlet cable gland**  
See page 12  
[AJBOX1]

# INSTALLATION

## MOUNTING THE UNIT

Each Dyna Drum SO fixture includes a sturdy yoke mount with multiple holes in its base for various fixing options. Dyna Drum SO fixtures weigh 30.6lbs (13.8Kg) - ensure that the mounting surface and the fixings used are sufficiently rated for the task.

When mounting a Dyna Drum SO fixture off ground, ensure that a suitably rated safety wire links the anchor hole at the rear of the Dyna Drum SO with a suitably sturdy secondary fixing point.

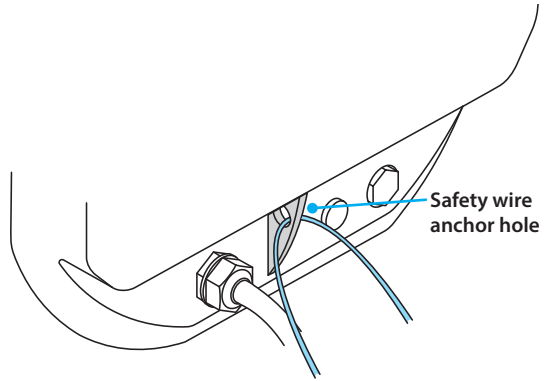

The yoke adjusters on each side of the Dyna Drum SO require a 5/16" (8mm) Allen (hex) wrench to focus the fixture. A useful angle chart is provided on each side to assist with initial adjustment.

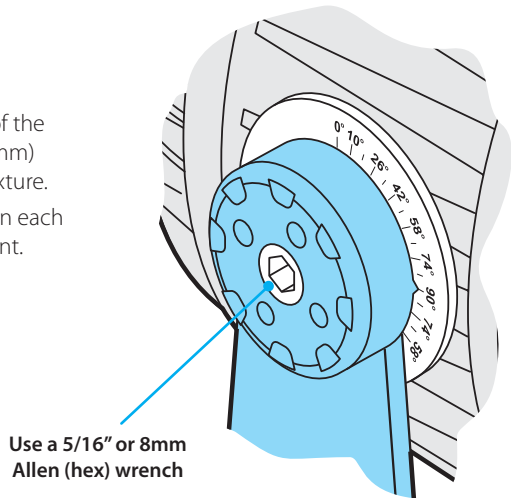

When installing each Dyna Drum SO fixture, ensure that the surface is level and that nothing is protruding to damage the mounting yoke. The yoke has multiple mounting holes and is designed to be surface mounted. Approved mounting surfaces include steel, aluminum, concrete or wood structures. Bolts or screws (not supplied) should be suitable for the surface (and the weight of the fixture) and ensure a secure mount for the fixture.

## USING A TENON MOUNT

Optional tenon mounts are available for use when a Dyna Drum SO needs to be mounted **on top** of a vertical pole. Tenon mounts are available for use with 2" (50mm) and 4" (100mm) poles of sufficient rigidity for the weight of the fixture.

**IMPORTANT: Tenon mounts are suitable only for vertical pole mounting where the fixture sits on top of the pole. Tenon mounts must NEVER be used to hang a Dyna Drum SO below a pole. For pendant-type installations, please enquire about the Dyna Drum SO Pendant model.**

### TO USE A TENON MOUNT

- 1 Slide the tenon mount onto the vertical pole and secure using the two bolts on the side (1/4" /6mm Allen (hex) wrench required).
- 2 Fix the Dyna Drum SO to the tenon mount using the supplied main bolt (17mm A/F wrench required) and pan control bolt (1/4" /6mm Allen (hex) wrench required) as shown right.

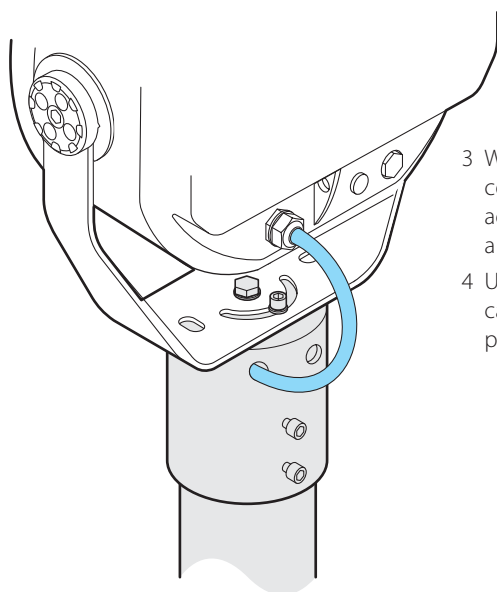
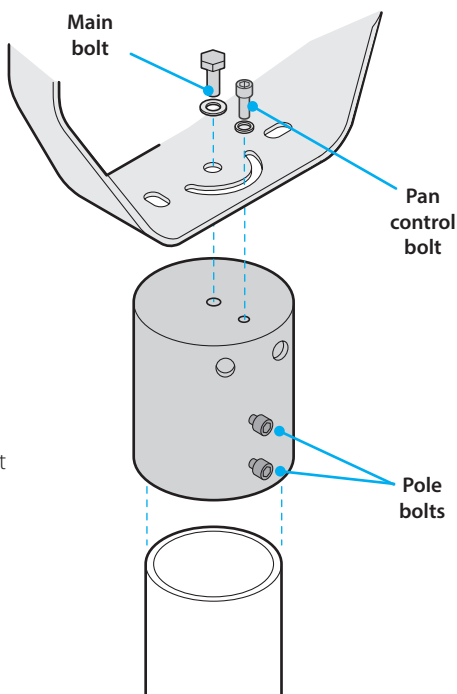

- 3 Where required, feed the mains/control cable into one of the two access holes and down the pole to a suitable exit point.
- 4 Use a suitable silicone sealant to cap off the cable access holes to prevent water ingress.



## USING A PIPE CLAMP

Optional pipe clamps are available to mount Dyna Drum SO fixtures on either 2" (50mm) or 4" (100mm) tubes and poles.

**IMPORTANT: Ensure the pipe and its mountings have sufficient load capacity for the Dyna Drum SO fixture(s) to be mounted.**

### TO USE A PIPE CLAMP

- 1 Separate the two halves of the clamp, if they are already bolted together.
- 2 Place the two halves of the clamp around the pipe.
- 3 Use the two longer bolts, one from each side to join the two halves - see below about the correct use of the supplied washers.
- 4 Tighten the two main bolts evenly until the clamp is held firmly in place.
- 5 Use the two smaller bolts (with spring and standard washers) to fix the Dyna Drum SO yoke of the clamp and tighten.

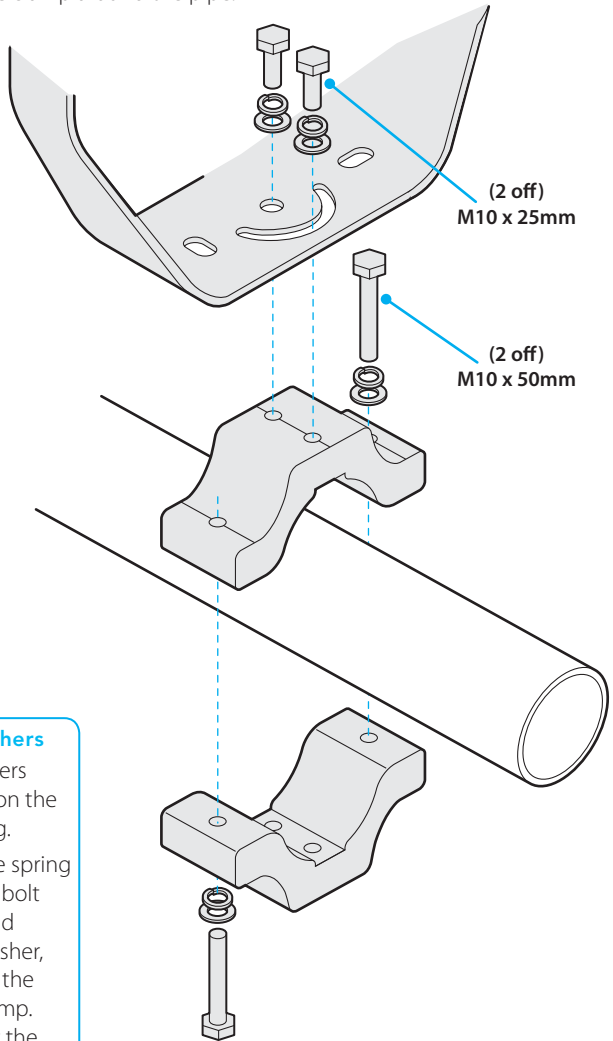

#### Using the supplied washers

The supplied spring washers help to maintain tension on the bolts to prevent loosening.

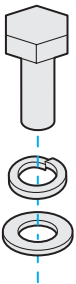

Always place the spring washer on each bolt first and then add the standard washer, before inserting the bolt into the clamp. This will prevent the steel spring washer from denting the softer aluminum body of the clamp.

## FITTING A SPREAD LENS

You can widen the native beam angle using a spread lens. It is possible to use both a spread lens and a snoot. Fit the lens first and then add the snoot.

*Tip: Adding accessories is much easier if the Dyna Drum SO front face is pointing vertically upwards.*

- 1 Using a 3/16" (4mm) Allen (hex) wrench, remove the four bolts that secure the front ring and remove the ring.
- 2 Remove the protective films on each side of the lens and place it into the inner ring of the emitter face. **IMPORTANT: The frosted side of the lens must facing inwards towards the emitters.**

To allow water drainage, the six notches of lens' rubber surround **must face outwards** and be placed so that two of the notches are vertically aligned with the fixture.

**IMPORTANT: The frosted side of the lens must face inwards to the emitters.**  
To allow water drainage, ensure that two of the notches (in the lens' rubber surround) are vertically aligned with the fixture.

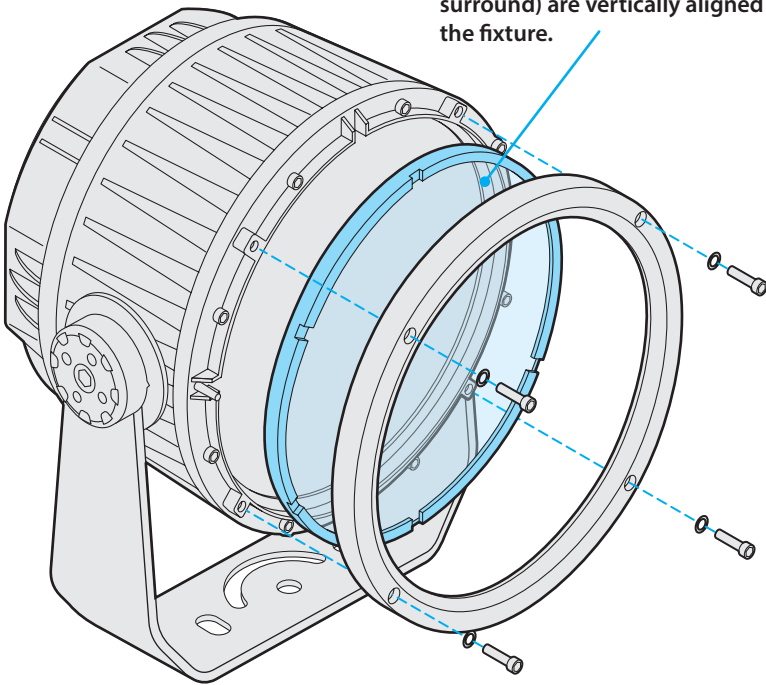

- 3 Replace the front ring.
- 4 Tighten the bolts evenly.

## FITTING A SNOOT

Snoots help to reduce or eliminate light spill into unwanted areas. The full and half snoots available from Acclaim Lighting are attached to the Dyna Drum SO units in the same way. It is possible to use both a spread lens and a snoot. Fit the lens first and then add the snoot.

*Tip: Adding accessories is much easier if the Dyna Drum SO front face is pointing vertically upwards.*

- 1 Using a 3/16" (4mm) Allen (hex) wrench, remove the four bolts that secure the front ring.
- 2 Remove the front ring and place the snoot onto the front of the fixture. The snoot mounting holes must align with the same threads that are used by front ring. There are also two small slots either side of the snoot that must fit onto the small locating pins either side of the fixture.

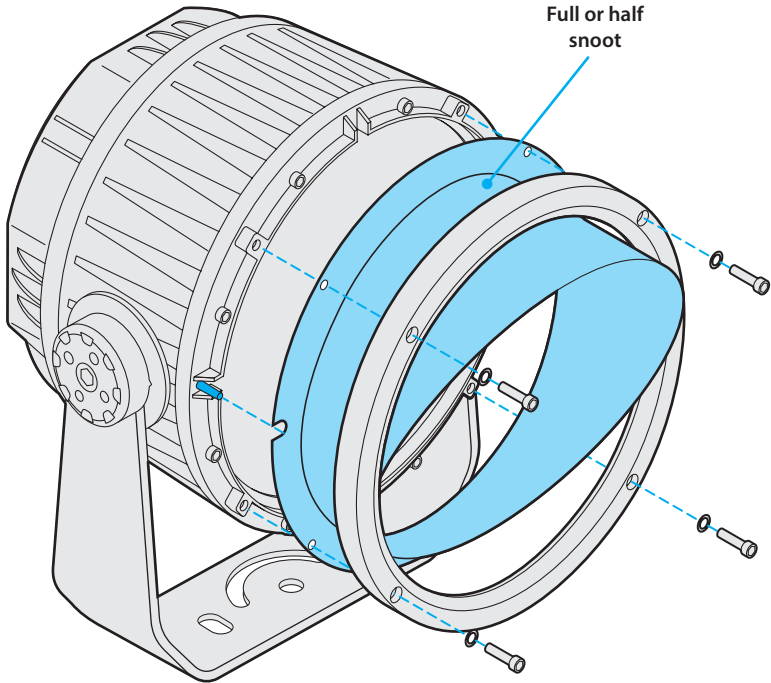

- 3 Replace the front ring.
- 4 Tighten the bolts evenly.

## POWER AND CONTROL WIRING

The combined power and control cord (roughly five feet, 1.5m in length) enters the casing via a water-tight gland at the rear of the fixture. The cord can be supplied either with bare tails or an Outdoor Linking System connector (see page 13).

For models with bare tails, the power cord color designations are as follows:

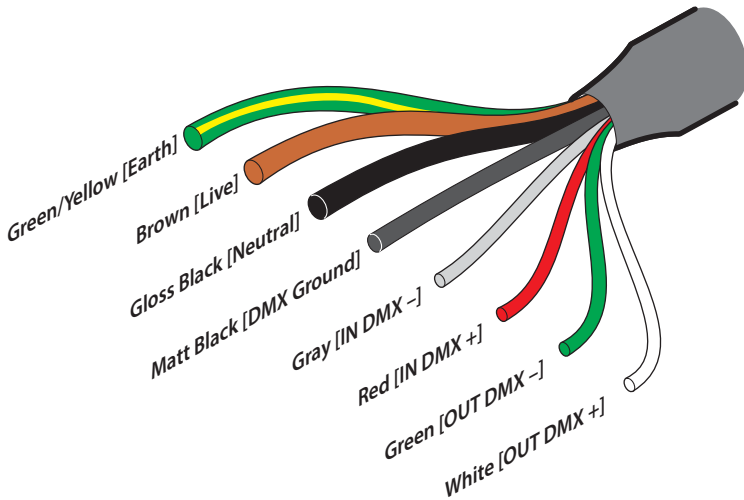

The power requirements are as follows:

- Voltage: 100-277VAC 50/60Hz
- Power: 135 or 150W steady state (according to model)

*Note: Acclaim recommends taking proper precautions for external surge protection, as control and power electronics can be damaged by major events.*

The DMX header cable connected to the feed cable should be suited for RS-485 data transmission and have a characteristic impedance of 120 Ohms, such as Belden 9842 or equivalent.

Ensure that:

- the mains input is derived from a suitable overload-protected supply.
- all cable access points, plus the enclosure cover are correctly sealed.
- all local codes are followed during planning and installation.
- only suitable cable connectors are used within the junction box.
- connections are made, inspected and certified by a qualified electrician.

## IN-RUSH CURRENT

Although LED fixtures are low power devices compared to their incandescent equivalents, their power supplies exhibit a trait known as 'in-rush current' when they are first powered on. This is caused by the various components within the switching power supplies topping themselves up with power. The in-rush current period lasts only milliseconds and does not cause any effect when a handful of units are powered on at the exact same time. However, if many fixtures are linked to the same power input, they will momentarily pull a current that may greatly exceed their normal operating level. This may affect over-current trips when power is applied. For this reason it is advisable to limit the number of fixtures on any one power input.

## WIRED DMX CONTROL

When connecting multiple fixtures, without the Outdoor Linking System options, connect the DMX output of the controlling device to the input wires of the first fixture and feed the output of that fixture to the next. The final fixture in the line should have a 120Ω terminating resistor connected between its DMX + (white) and DMX – (green) output lines:

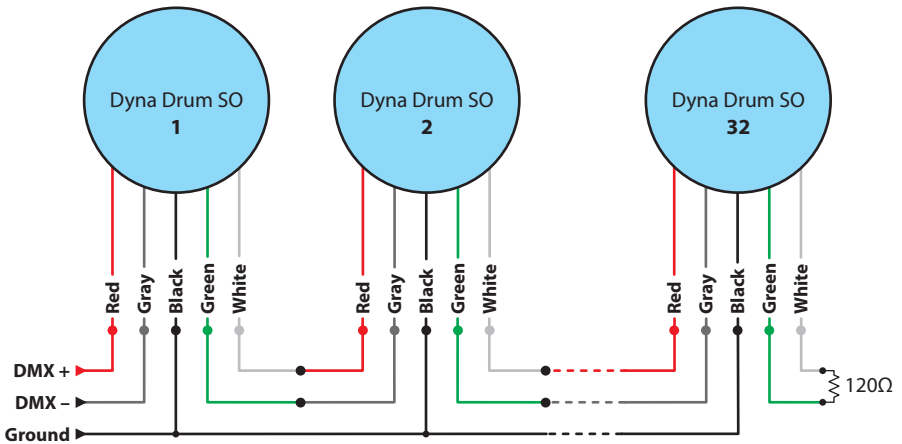

Acclaim requires Belden 9842 or approved equivalent for all DMX wiring applications.

## TIPS FOR ACHIEVING SUCCESSFUL DMX CONTROL

- Do not exceed a total cable length of 3,900 ft (1200m) without buffering.
- Do not exceed a total of 32 fixtures on a single line without buffering.
- Use only connection cables with a characteristic impedance of 120Ω, preferably where the DMX + and DMX – data lines are twisted around each other and the ground link exists as a coaxial screen surrounding the inner cores.
- Connect a 120Ω terminating resistor between the DMX + and DMX – output connections of the final fixture.
- Do not introduce a passive Y-split into the control cabling. If it is necessary to split the control link in order feed fixtures located in different directions, use a powered DMX splitter/buffer.
- Ensure that the DMX + and DMX – connections do not become crossed at any point.

## INPUT WIRING PROTECTION

Ensure that appropriate care is taken to protect the junction where the mains and control inputs are joined to the feed cable. The Acclaim Lighting AJBOX1 is an IP66-rated junction box which provides separated AC power and DMX control inputs for connection to a combined feed cable:

See page 13 for details about the Outdoor Linking System.

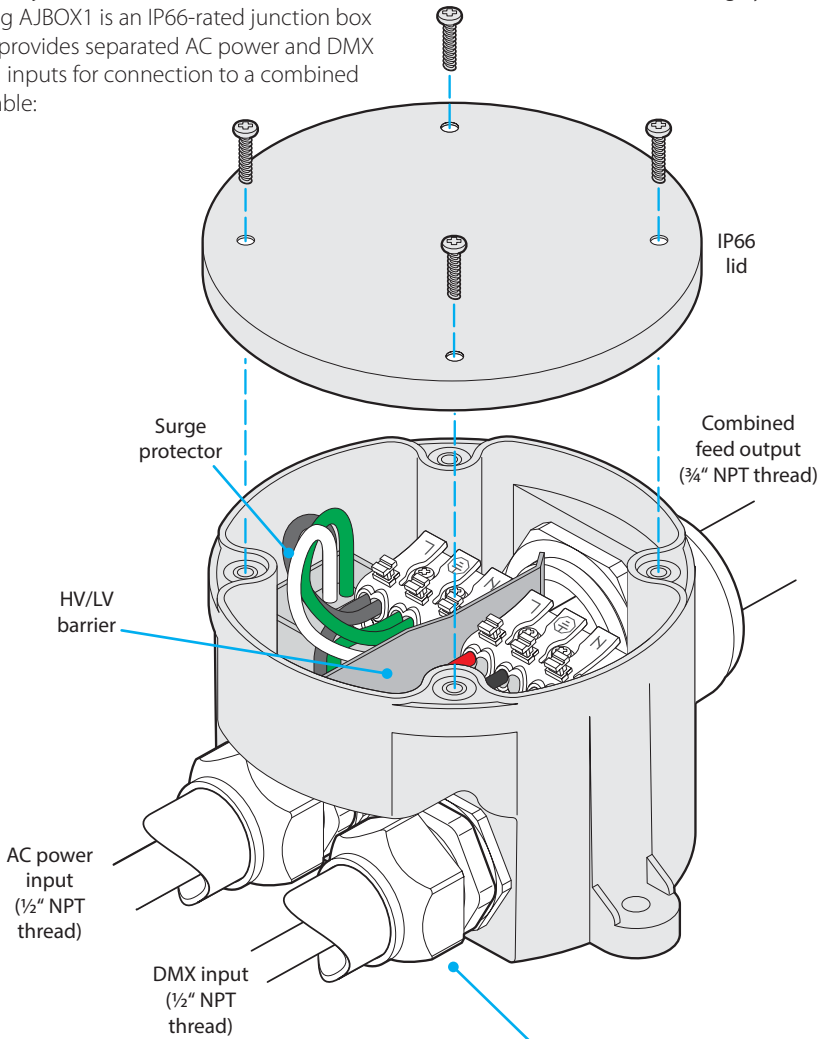

### INPUT FIXTURES/GLANDS

You will need to source 3rd-party conduit fixtures/cable glands for the inputs, as suits your installation. The large cable gland for the output is provided with the AJBOX1.

Shown here with cable gland inputs rather than conduit fixtures

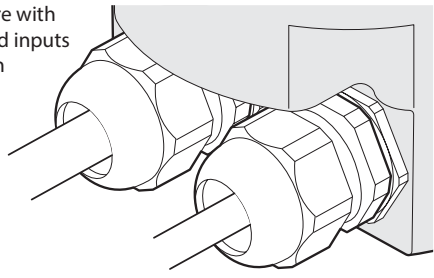

## CABLING WITH OLS

Dyna Drums can be specified with Outdoor Link System connectors pre-fitted instead of bare tails. OLS greatly simplifies the task of distributing power and control to multiple fixtures.



OLS is a collection of feed and link cables (of various lengths) plus a T-junction and a terminator, all utilizing IP67-rated connectors together with robust all-weather construction. The input to each stage is signified by a connector with a blue collar, while all outputs have connectors with black collars. The blue and black connectors mate quickly and easily, with a twist of the collar to lock them securely in place.

A typical configuration is shown on the next page.

For part numbers, see page 4.

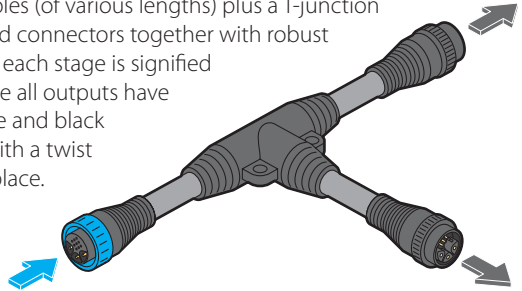

## LIMITS

Feed current must not exceed 15A, which results in the realistic limits listed here:

	120VAC	230VAC	277VAC
Line voltage	120VAC	230VAC	277VAC
Max power	1,800W	3,450W	4,155W
Max run length	150'	300'	350'
Max number of Dyna Drum SO fixtures:			
White	13	25	30
SCS/Quad	12	23	27

## FEED CABLE CONNECTIONS

Each feed cable provides bare tail connections suitable for termination within an all-weather junction box, such as the AJBOX1:

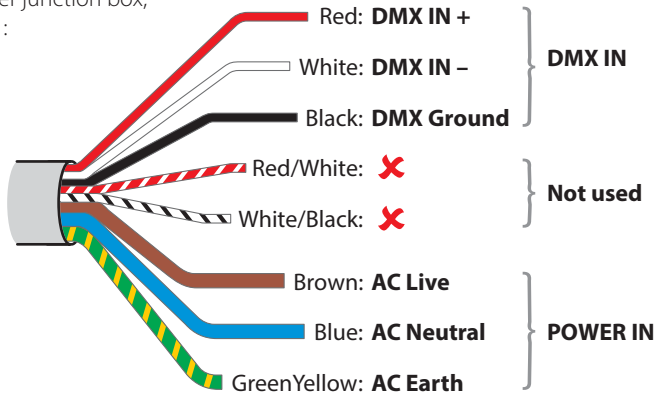

## TYPICAL OLS CONFIGURATION

**IMPORTANT:** A terminator must be fitted to the final T-junction to simultaneously protect the live connections and correctly terminate the DMX control feed.

If a link cable is used between any T-junction and a fixture input, the total length (from the T-junction to the fixture) must not exceed 10' (3m) in length.

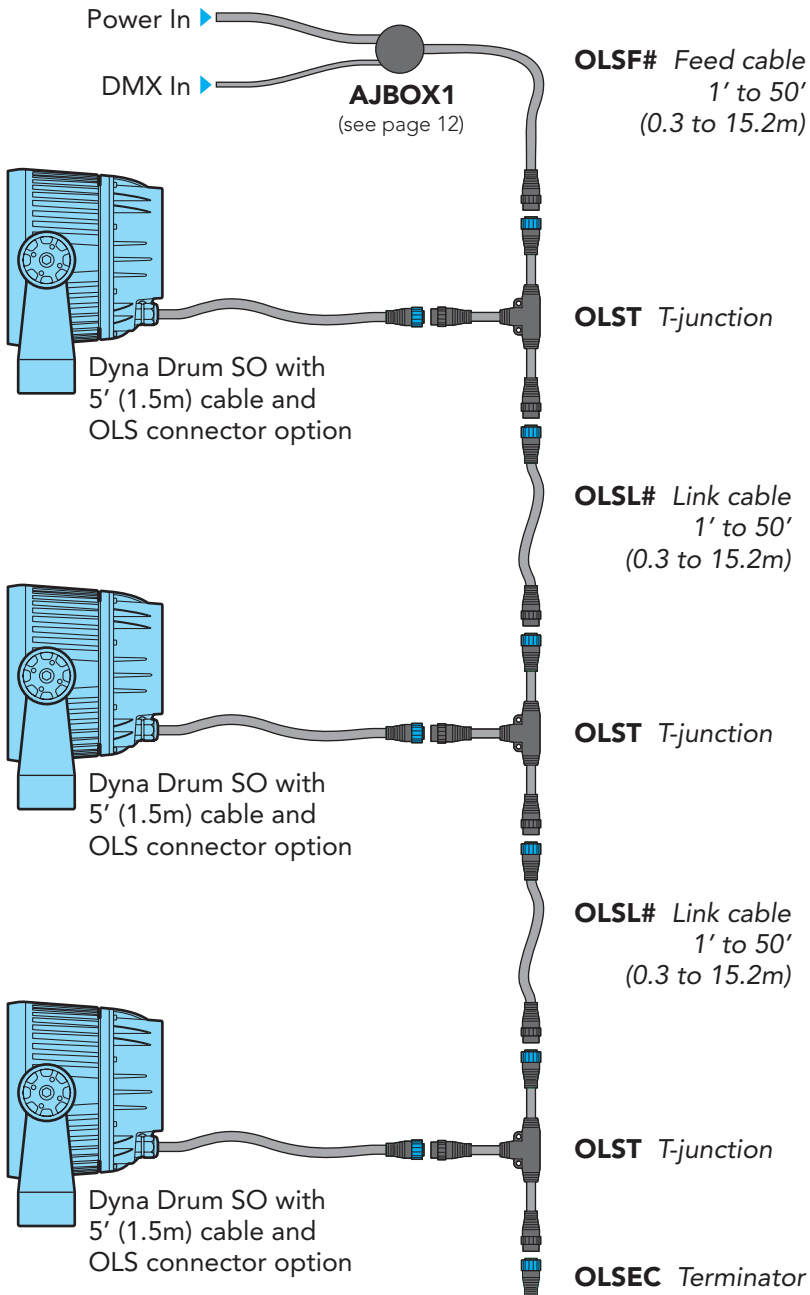



## WIRELESS DMX CONTROL

The embedded Aria™ wireless system allows you to control any number of Dyna Drum SO fixtures that are within range of an Aria transmitter set to use the same wireless channel:

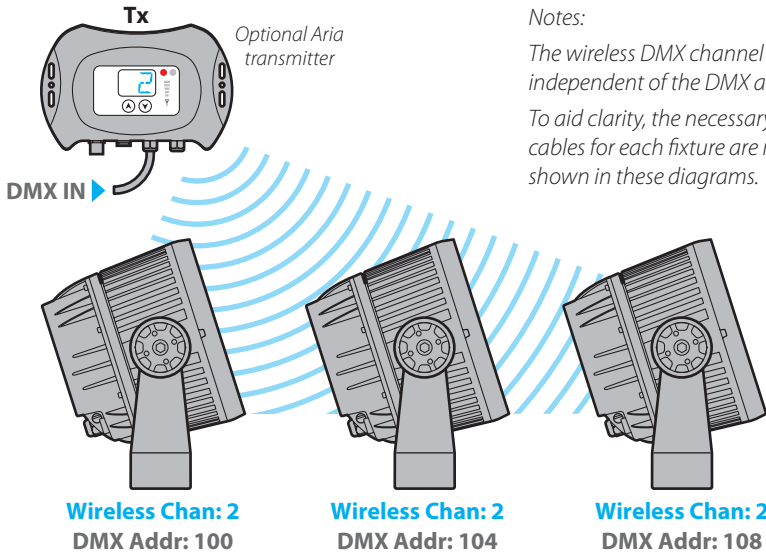

Notes:

The wireless DMX channel is totally independent of the DMX address.

To aid clarity, the necessary power cables for each fixture are not shown in these diagrams.

## USING A DYNA DRUM SO AS A WIRELESS HUB

When a Dyna Drum SO fixture receives a wireless input (and it has no wired DMX input signal), it will automatically output the full received DMX universe on its output wires. This means that you can wire through and control up to 32 non-Aria DMX fixtures (such as Pixel Graze), or more, if an active repeater is used.

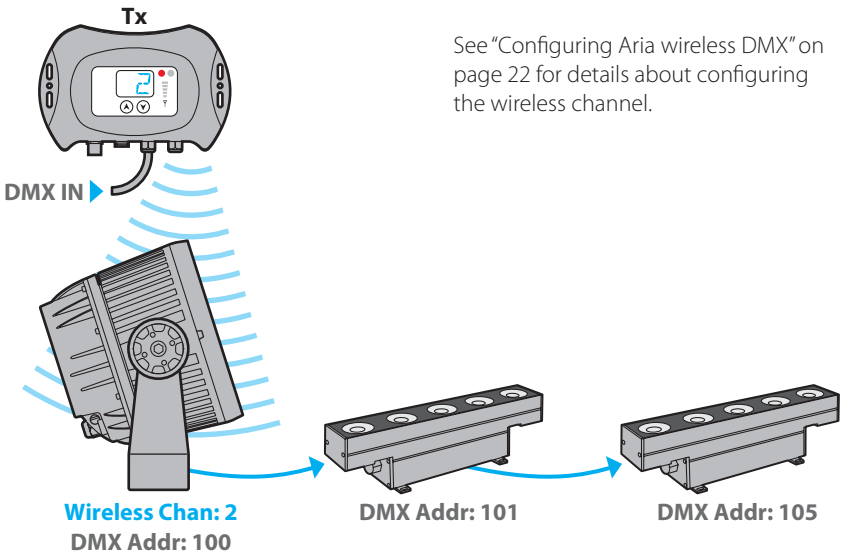

See “Configuring Aria wireless DMX” on page 22 for details about configuring the wireless channel.

Non-Aria equipped fixtures (e.g. Pixel Graze)

# CONFIGURATION

Operation of the fixture will commence as soon as power is applied and the user display on the rear panel will first show its model type and then show its current DMX address and number of channels. After a short period it will then blank out. The fixture may or may not immediately show output from its emitters - this will depend upon the settings within the menu and/or control input.

*Note: The sealed control buttons use capacitive sensors similar to your smartphone screen and will not respond to touch if you are wearing gloves.*

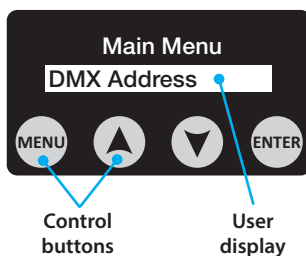

## ENTERING THE MENU

Press and hold the **MENU** button for roughly 7 seconds until the *Main Menu* entry is shown, then use the buttons to navigate the menu, as described below. The menu will automatically exit roughly eight seconds after the last button press.

For a certain period after the menu has first been entered, and then exited, you will only need to tap any button to re-enter. After that period a locked symbol  will be shown and you will need to once again press and hold the **MENU** button for roughly 7 seconds to unlock it.

## MENU NAVIGATION

Once you have entered the menu you can use the four control buttons to navigate around the menu and alter settings as necessary. The next page lists the main menu items.

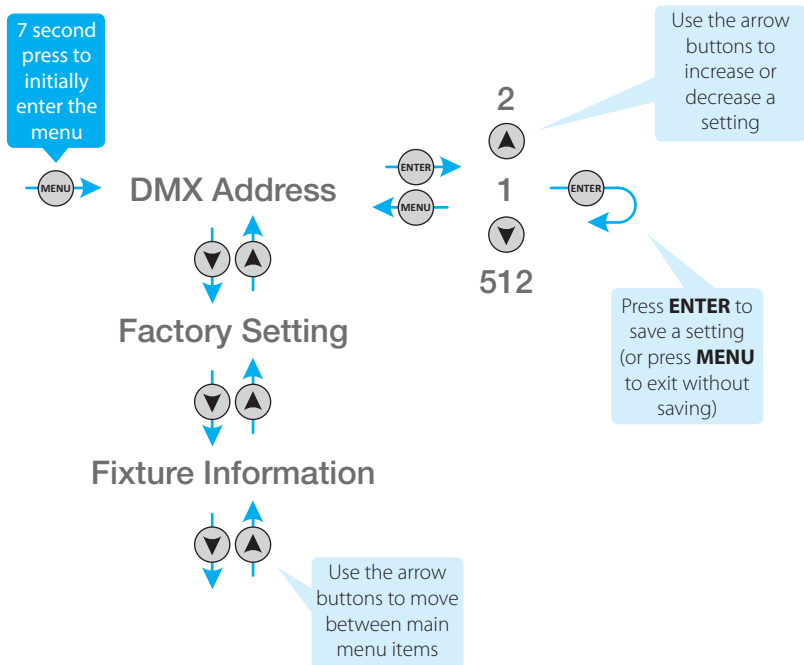

## MAIN MENU ITEMS

<b>DMX Address</b>	Allows you to set the DMX start address for this fixture. Depending on the model, between one and five DMX addresses are required. See page 18.
<b>Factory Setting</b>	Clears all user settings and returns all options to their default states. Also resets the DMX address to 1. See page 18.
<b>Fixture Information</b>	Provides various details including the current LED temperature, usage times and firmware version. See page 18.
<b>Gamma</b>	Defines the relationship between the input control values and how the various LED emitters respond across their dimming ranges, from 0 to 100%. See page 19.
<b>Frequency</b>	Determines the base frequency used to control the LED emitters. This can be changed to eliminate visible flickering on video images. See page 19.
<b>Display Setting</b>	Allows various changes to the user display, such as invert, backlight timeout, temperature units, etc. See page 20.
<b>Internal Color Mode</b>	Allows you to mix a static color that will be shown depending on the status of the DMX input and the setting of the Solo Behavior option. <i>Note: Single color models show Internal Output Mode.</i> See page 20.
<b>System Test</b>	Cycles through the various emitters to confirm correct operation. See page 21.
<b>White Balance</b>	Allows you to bias the red, green and/or blue intensities in order to achieve a particular white balance that will be reproduced when RGB mixes are requested. <i>Note: Not available on single color models.</i> See page 21.
<b>Aria Wireless DMX</b>	Determines the configuration of the internal wireless DMX receiver. See page 22.
<b>Photocell</b>	Determines the configuration of the internal photocell automation features. See page 23.
<b>Solo Behavior</b>	Determines how the fixture should behave when there is no external control input. See page 24.



## SETTING THE DMX ADDRESS

When external control (wired or wireless) is used, the DMX start address of the fixture needs to match the start address being used by the controlling device. Color fixtures use four (or five) DMX channels (for Red, Green, Blue and White (and/or Amber)), beginning with the one chosen here; white-only models require just one DMX channel and DW model require two channels.

Notes:

- The DMX address can also be configured via RDM, see page 25.
- The DMX address is completely independent of the Aria wireless radio channel setting.
- When a valid DMX input is attached to the Dyna Drum SO fixture it will override any internal color output.

### TO SET THE DMX ADDRESS

- 1 Enter the user menu (see page 16).
- 2 Press **ENTER** to choose the *DMX Address* menu item.
- 3 Use the **▼** and **▲** buttons to choose a start address from 1 to 509 (512 on white-only models).
- 4 Press **ENTER** to save. The DMX start address is now fixed.

## RETURNING TO FACTORY SETTINGS

This option returns the fixture to its default settings. The DMX address will be reset to 1.

### TO RETURN TO FACTORY SETTINGS

- 1 Enter the user menu (see page 16).
- 2 Use the **▼** button to locate the *Factory Setting* option and press **ENTER**. The display will show *Reset to Factory Defaults*.
- 3 Press **ENTER**. The display will show *Are you sure?*
- 4 Use the **▼** button to show *Yes* and press **ENTER**.

## VIEWING FIXTURE INFORMATION

This option contains four useful information read-outs:

- **LED Temperature** - shows the current temperature measured at the centre of the LED emitter face. See page 20 for details about changing the temperature read-out units between °F and °C, and also about enabling over-temperature warnings.
- **Firmware Version** - displays the software versions for both the boot loader and the main application.
- **LED Usage** - displays the total number of hours that the LED emitters have been raised above 0% output.
- **Fixture Usage** - displays the total number of hours that the fixture has been powered on.

*Note: All of these items are for information only, no changes are possible.*

### TO VIEW FIXTURE INFORMATION

- 1 Enter the user menu (see page 16).
- 2 Use the **▼** or **▲** buttons to locate the *Fixture Information* option and press **ENTER**.
- 3 Use the **▼** or **▲** buttons to locate the required read-out and press **ENTER**.

## ADJUSTING THE GAMMA SETTING

Like most light sources, the manner in which LED emitters operate means they exhibit a non-linear response. This means that to achieve changes in output levels which look proportional and correct to the eye (and particularly when filmed), it is necessary to vary the rate of change at the lower and upper ends of the dimming range in comparison to the middle. This is achieved using an in-built dimming response curve.

As a high specification fixture, the Dyna Drum SO provides the option to adjust the nature of the dimming response curve so that the emitters (for every color) respond differently for given control input levels. This is referred to as the *Gamma* setting. By default, the gamma setting is set to **No** to produce a mild and progressive response. If the gamma setting is enabled and increased, from **2.0** through to **2.8**, you will notice a higher response to dimming changes, particularly at the lower end. The graph above simulates the effects upon dimming (applied equally to each color) of choosing the various gamma setting options.

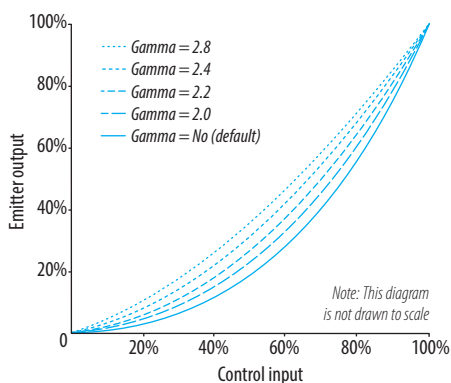

### TO ADJUST THE GAMMA SETTING

- 1 Enter the user menu (see page 16).
- 2 Use the **▼** or **▲** buttons to locate the **Gamma** option and press **ENTER**. The current Gamma setting will be shown.
- 3 Press **ENTER** and then use the **▼** or **▲** buttons to show the required gamma setting.
- 4 Press **ENTER** to set the new gamma value.

## ADJUSTING THE PWM FREQUENCY

As with most LED fixtures, the Dyna Drum SO dims its emitters by using a technique called *Pulse Width Modulation (PWM)*. This involves switching the emitters on and off at a high frequency and then varying the lengths of the respective on and off periods according to the required dimming level. The frequencies used all lie beyond the ability of the naked eye to distinguish the on/off transitions, however, some camera systems can detect flickers at certain frequencies. To solve this potential issue, the Dyna Drum SO allows you to change the default 1200Hz base PWM frequency to lower, or much higher ones that respond better to particular camera issues. Options range from 900 to 25,000Hz.

### TO ADJUST THE PWM FREQUENCY SETTING

- 1 Enter the user menu (see page 16).
- 2 Use the **▼** or **▲** buttons to locate the **Frequency** option and press **ENTER**. The current PWM base frequency will be shown.
- 3 Press **ENTER** and then use the **▼** or **▲** buttons to show the required frequency.
- 4 Press **ENTER** to set the new value.

## CHANGING THE DISPLAY SETTINGS

This option contains four settings related directly to the user display:

- **Invert** - allows you to invert the text on the user display so that it reads correctly when the fixture is mounted upside-down.
- **Display Warning** - when set to On, a warning will appear on the display if the internal temperature becomes too high, either due to the external environment or an internal issue. The message reads: *Temperature warning - please check fixture.*  
*Note: In addition to showing a warning, the fixture will protect its emitters by automatically reducing output to 50% if the maximum allowable operating temperature is exceeded. If the over-temperature condition persists for more than 10 minutes, the fixture will close itself down.*
- **Temperature Unit** - allows you to change between °F and °C when displaying readings in the *Fixture Information > LED Temperature* section.
- **Display Backlight Timeout** - determines whether the user display should automatically blank out when it is not being used, or should remain on permanently to allow the DMX address to be seen at all times. When set to Off, the time-out feature will be disabled and the display will not blank out.

### TO CHANGE DISPLAY SETTINGS

- 1 Enter the user menu (see page 16).
- 2 Use the **▼** or **▲** buttons to locate the *Display Setting* option and press **ENTER**.
- 3 Use the **▼** or **▲** buttons to locate the required sub-option and press **ENTER**.
- 4 Use the **▼** or **▲** buttons to change the sub-option setting and press **ENTER**.

## SETTING AN INTERNAL COLOR/OUTPUT

This option allows you to mix a static color (or choose a white dimming level on single color models) which will be displayed whenever the following two criteria are met:

- The *Solo Behavior* option is set to *Internal Color Mode* (or *Internal Output Mode*) and,
- There is no DMX input signal.

Once configured, you need to activate the *Solo Behavior > Internal Color/Output Mode*. See page 24.

### TO SET AN INTERNAL COLOR/OUTPUT

- 1 Enter the user menu (see page 16).
- 2 Use the **▼** or **▲** buttons to locate the *Internal Color Mode* (or *Internal Output Mode* - on single color models) option and press **ENTER**.
- 3 On color models, use the **▼** or **▲** buttons to locate the required color sub-option.
- 4 Press **ENTER**.
- 5 Use the **▼** or **▲** buttons to change the dimming setting and press **ENTER**.
- 6 Repeat steps 3 to 5 on color models until the required overall color output is achieved.

## RUNNING A SYSTEM TEST

This option assists in testing all of the emitters. When engaged, the emitters will flash on and off. Color models will cycle in turn through the various emitter colors.

*Note: You can also test the emitters remotely via RDM, see page 28.*

### TO RUN A SYSTEM TEST

- 1 Enter the user menu (see page 16).
- 2 Use the **▼** or **▲** buttons to locate the **System Test** option and press **ENTER**. The fixture will change between emitter outputs. The user display will flash **Testing.....** while the test proceeds.
- 3 Press either the **MENU** or the **ENTER** buttons to halt the test.

## SETTING A WHITE BALANCE

*Note: White balance is only possible on Dyna Drum SO color models.*

White balance is useful when your Dyna Drum SO installation will be required to regularly present particular shades of white using the R, G, B emitters, (plus the white emitters, if necessary). Using the white balance feature you can 'bias' particular colors so that when the R, G and B channels are all brought up, your pre-programmed bias will achieve, for example, a balanced warm white derived from a significant red output, with a moderate green output, while the blue is scaled back.

To achieve identical white balance across a collection of fixtures, you will need to program the same settings on each Dyna Drum SO unit.

### TO SET A WHITE BALANCE

- 1 Enter the user menu (see page 16).
- 2 Use the **▼** or **▲** buttons to locate the **White Balance** option and press **ENTER**. You now have access to the separate **Red**, **Green** and **Blue** options, which are all set to 255 by default.
- 3 Use the **▼** or **▲** buttons to choose a color and press **ENTER**.
- 4 Use the **▼** or **▲** buttons to reduce the chosen color from 255 down to a minimum of 125 to reduce the intensity of that color, and press **ENTER** to save.
- 5 Repeat step 4 for each color that needs to be biased to achieve the required balance.

### TO CANCEL A WHITE BALANCE

- 1 Enter the user menu (see page 16).
- 2 Select the **White Balance** option. In turn visit each color and ensure that they are all returned to 255.

## CONFIGURING ARIA WIRELESS DMX

Each Dyna Drum SO fixture includes an internal Aria™ wireless DMX receiver unit to allow it to be remotely controlled by an Acclaim Lighting Aria transmitter. Fifteen radio channels are available to choose from, allowing you to avoid potential interference sources, such as WiFi access points, and set up parallel wireless links between different sets of Aria units. Dyna Drum SO fixtures are shipped with the wireless system disabled and the radio channel set to 0 as standard. For more details about choosing the most suitable radio channel, see page 30.



Notes:

- The Aria wireless radio channel setting can also be configured via RDM, see page 26.
- The Aria wireless radio channel setting is completely independent of the DMX address.
- If a valid wired DMX control input is applied to the fixture, it will take precedence over the Aria wireless control link.

### TO CONFIGURE ARIA WIRELESS DMX

- 1 Enter the user menu (see page 16).
- 2 Use the **▼** or **▲** buttons to locate the *Aria Wireless DMX* option and press **ENTER**. The display will show *Wireless On/Off*.
- 3 Press **ENTER**. If the display shows *Off*, use the **▼** or **▲** buttons to change the entry to *On* and press **ENTER**.
- 4 Use the **▼** or **▲** buttons to show *Wireless Channel* and press **ENTER**.
- 5 Use the **▼** or **▲** buttons to choose the required radio channel (from 0 to 14 - to match that used by the Aria transmitter) and press **ENTER**.

*Note: Ensure your Aria transmitter and any other related fixtures are set to use the same wireless radio channel.*



## USING THE AUTOMATION FEATURES (PHOTOCELL)

The fixture includes two related features which allow you to automate standalone operation:

- The in-built photocell can enable fixture output (at 100%) when the ambient light level falls below a pre-determined level.
- The auto shutoff timer determines how long the fixture should remain outputting after it has been triggered by the photocell.

These automated features operate only in standalone mode, i.e. with no external wired or wireless DMX control input.

*Note: The automation features can also be configured via RDM, see page 27.*

### TO CONFIGURE THE AUTOMATION FEATURES

- 1 Enter the user menu (see page 16).
- 2 Use the **▼** or **▲** buttons to locate the *Photocell* option and press **ENTER**. The display will show *Photocell On/Off*.
- 3 Press **ENTER**. If the display shows *Off*, use the **▼** or **▲** buttons to change the entry to *On* and press **ENTER**.
- 4 Use the **▼** or **▲** buttons to show *Photocell Timer* and press **ENTER**. The display will show the number of hours that the fixture is currently configured to show output, once triggered by the photocell.
- 5 Use the **▼** or **▲** buttons to show the required number of hours (from 1 to 24) and press **ENTER**.
- 6 Use the **▼** or **▲** buttons to show *Photocell Sensitivity* and press **ENTER**. The display will show the ambient light level at which the fixture should begin outputting (**100** is the most sensitive to light). Some experimentation will be required to determine the optimum setting (the default is 70).
- 7 Use the **▼** or **▲** buttons to show the required sensitivity setting (from 0 to 100) and press **ENTER**.





*Note: For the photocell feature to operate, ensure that no DMX signal is received by the fixture. Color models will output all colors at 100% when triggered.*

## DETERMINING SOLO BEHAVIOR

You can choose how the fixture should behave when it is running solo, either because an external control input is not being used at all or because a connection has been temporarily lost. There are three solo behavior choices:

- **Black Out** - In this mode, when no external control is present, the emitter output will be extinguished.
- **Internal Color/Output Mode** - In this mode, when no external control is present, the fixture can be made to show a pre-programmed static color. Ensure that an internal color mix, or dimmed white output setting is stored within the *Internal Color Mode* (or *Internal Output Mode*) option. For details about creating static color mixes, see page 20.
- **Hold Last DMX Value** - In this mode, when no external control is present, the emitter output will remain as per the last received instruction.

### TO DETERMINE THE SOLO BEHAVIOR

- 1 Enter the user menu (see page 16).
- 2 Use the  or  buttons to locate the *Solo Behavior* option and press **ENTER**. The display will show the currently selected solo behavior mode .
- 3 Use the  or  buttons to show the required solo behavior mode and press **ENTER**.

## CONFIGURATION VIA RDM

The use of RDM (Remote Device Management) with the Dyna Drum SO series is optional and allows the following tasks to be completed remotely without having to visit each fixture:

- Configure the DMX address,
- Set the wireless channel,
- Set the automation features (photocell),
- Test the emitter outputs.

Various third party DMX/RDM tools are available; Acclaim Lighting recommends the XMT-350.

## CONFIGURING THE DMX ADDRESS VIA RDM

When external control (wired or wireless) is used, the DMX start address of the fixture needs to match the start address being used by the controlling device. Color fixtures use four (or five) DMX channels (for Red, Green, Blue and White (and/or Amber)), beginning with the one chosen here; white-only models require just one DMX channel.

*Note: The DMX address is completely independent of the Aria wireless channel setting.*

### TO CONFIGURE THE DMX ADDRESS USING THE XMT-350

- 1 Connect the XMT-350 to the DMX input line of the Dyna Drum SO installation.
- 2 On the XMT-350, press the **MODE** button, then use the arrow buttons to highlight the **RDM** function and press the  button to select. The XMT-350 will search for RDM devices and after a short while the XMT-350 will display a list of all located fixtures:

MAIN	PATCH	OPTIONS	003/003
DYNA DRUM SO WHITE 4000K (001)			
DYNA DRUM SO SCS RGBAW 002			
DYNA DRUM SO COLOR QS 007			

The fixture highlighted in the list should show output from its emitters to identify itself.

- 3 On the XMT-350, press the right arrow button to change to the **PATCH** tab:

MAIN	PATCH	OPTIONS	003/003
▶ RESTART PATCHING			
DYNA DRUM SO WHITE 40... (001)			
DYNA DRUM SO SCS RGBW (002)			
DYNA DRUM SO COLOR QS (007)			

*Note: DMX addresses shown in brackets, e.g. (001), have been temporarily assigned by the XMT-350, but are not yet stored within the fixture(s).*

- 4 If necessary, use the up/down buttons to choose an alternative fixture.
- 5 Press the  button to set the address for the currently highlighted fixture:

ACTUAL ADDRESS:	001
PATCH TO ADDRESS:	<input type="text" value="001"/>
✓ OK    ✕ CANCEL	

- 6 Use the up/down buttons to set the required DMX address and then press the  button to store it within the fixture.
- 7 The highlight will automatically move to the next fixture so that you can address it. Repeat steps 4 to 6 until all fixtures are addressed.

## SETTING THE WIRELESS CHANNEL VIA RDM

For general information about using wireless control, see page 15. For details about choosing channels and locations, see page 30.

### TO SET THE WIRELESS CHANNEL USING THE XMT-350

- 1 Connect the XMT-350 to the DMX input line of the Dyna Drum SO installation.
- 2 On the XMT-350, press the **MODE** button, then use the arrow buttons to highlight the **RDM** function and press the **✓** button to select. The XMT-350 will search for RDM devices and after a short while the XMT-350 will display a list of all located fixtures. The fixture highlighted in the list should show output from its emitters to identify itself.
- 3 If necessary, use the up/down buttons to highlight an alternative fixture.
- 4 Press the **✓** button to view details for the chosen fixture and then use the down button to highlight the **MODEL** entry:

<b>DYNA DRUM SO WHITE 4000K</b>	
▶ <b>LABEL:</b>	DYNA DRUM SO WHITE ...
▶ <b>MODEL:</b>	DYNA DRUM SO WHITE ...
<b>MAN:</b>	ACCLAIM LIGHTING
▶ <b>DMX START ADDRESS:</b>	001
<b>DMX PERSONALITY:MODE1:</b>	1-SL...
<b>DMX SLOTS:</b>	1

- 5 Press the **✓** button to view the options:

<b>DYNA DRUM SO WHITE 4000K</b>	
▶ <b>WIRELESS ON/OFF</b>	ON
▶ <b>WIRELESS ADDR</b>	0
▶ <b>PHOTO SENS. ON/OFF</b>	ON
▶ <b>PHOTO SENS. VALUE</b>	70
▶ <b>LED ON TIME ON LIGHT</b>	10

Within this menu, you can change the radio address and also enable/disable the wireless receiver circuit.

- 6 If the **WIRELESS ON/OFF** entry is set to OFF, highlight the option and press the **✓** button. Use the up/down buttons to select the ON entry and press the **✓** button.
- 7 Highlight the **WIRELESS ADDR** option and press the **✓** button. Use the up/down buttons to select the required address (between 0 and 14) and press the **✓** button. For more details about choosing the most suitable radio channel, see page 30.

*Note: Ensure the Aria transmitter and any other related fixtures are set to use the same wireless radio channel.*

- 8 Press the **X** button to return to the previous screen.

## SETTING THE AUTOMATION FEATURES (PHOTOCELL) VIA RDM

The fixture includes two related features that allow you to automate standalone operation:

- The in-built photocell can enable fixture output (at 100%) when the ambient light level falls below a pre-determined level.
- The auto shutoff timer determines how long the fixture should remain outputting after it has been triggered by the photocell.

These automated features operate only in standalone mode, i.e. with no external DMX control input.

### TO SET THE AUTOMATION FEATURES USING THE XMT-350

- 1 Connect the XMT-350 to the DMX input line of the Dyna Drum SO installation.
- 2 On the XMT-350, press the **MODE** button, then use the arrow buttons to highlight the **RDM** function and press the **✓** button to select. The XMT-350 will search for RDM devices and after a short while the XMT-350 will display a list of all located fixtures. The fixture highlighted in the list should show output from its emitters to identify itself.
- 3 If necessary, use the up/down buttons to highlight an alternative fixture.
- 4 Press the **✓** button to view details for the chosen fixture and then use the down button to highlight the **MODEL** entry:

DYNA DRUM SO WHITE 4000K	
▶ LABEL:	DYNA DRUM SO WHITE ...
▶ MODEL:	DYNA DRUM SO WHITE ...
MAN:	ACCLAIM LIGHTING
▶ DMX START ADDRESS:	001
DMX PERSONALITY: MODE1:	1-SL...
DMX SLOTS:	1

- 5 Press the **✓** button to view the options:

DYNA DRUM SO WHITE 4000K	
▶ WIRELESS ON/OFF	ON
▶ WIRELESS ADDR	0
▶ PHOTO SENS. ON/OFF	ON
▶ PHOTO SENS. VALUE	70
▶ LED ON TIME ON LIGHT	10

- 6 Use the lower three options to set your parameters:
  - PHOTO SENS. ON/OFF - enables/disables the photocell system.
  - PHOTO SENS. VALUE - determines the required ambient light level at which the fixture should begin outputting (**100** is the most sensitive to light). Some experimentation will be required to determine the optimum setting (the default is 70).
  - LED ON TIME ON LIGHT - determines the number of hours (starting from the photocell trigger) that light output should continue before being extinguished. The options range from **1** to **24** hours (the default is 10 hours).
- 7 Press the **X** button to return to the previous screen.

*Note: For the photocell feature to operate, ensure that no DMX signal is received by the fixture. Color models will output all colors at 100% when triggered.*

## TESTING EMITTER OUTPUT VIA RDM

After you have addressed each Dyna Drum SO fixture we recommend that you also test each one. This can be achieved either using the **System Test** option within the internal menu (see page 21) or using your RDM (Remote Device Management) tool. Various third party DMX/RDM tools are available; Acclaim Lighting recommends the XMT-350 for this task.

### TO TEST EMITTER OUTPUT USING THE XMT-350

- 1 Connect the XMT-350 to the DMX input line of the Dyna Drum SO installation.
- 2 Power on the fixture(s) and the XMT-350.
- 3 On the XMT-350, press the **MODE** button, then use the arrow buttons to highlight the **SEND** function and press the ✓ button to select.



- 4 Use the arrow buttons to determine the DMX output:
  - Use the left and right buttons to choose the DMX address,
  - Use the up and down buttons to increase/decrease the level at the chosen address.

*Note: If you wish to send DMX values to all addresses simultaneously (rather than cycling through them individually), when the XMT-350 is showing address 001, press the left button once to change to **ALL CHANNELS**. Now when you set the level it will affect all emitters equally.*

# FURTHER INFORMATION

## TROUBLESHOOTING

### NO LIGHT OUTPUT IS VISIBLE WHEN EXPECTED.

- Check that power is correctly applied to the fixture and that there is no damage to the power input cord.
- Use the menu to perform an emitter test.
- Use an RDM tool to perform an emitter test.
- Use the menu to check the internal temperature of the fixture.
- If external DMX control is being used, check that the DMX address set within the fixture matches that being output by the controlling source device.
- If external DMX control is being used, check the DMX output near to the source to confirm a valid signal is being originated. When a valid DMX input is attached to the Dyna Drum SO fixture, the user display will show the configured DMX address.
- If external DMX control is being used, check that the DMX + (hot) and DMX - (cold) lines have not been crossed.
- If the Internal Color/Output Mode is being used, check that the static color or white-only output has been correctly programmed (see page 20) and that the appropriate solo mode is selected (see page 24).
- If Aria wireless DMX control is being used, check that the fixture is set to the same wireless channel as the transmitter (the wireless channel is independent of the DMX address). Try changing the transmitter and receiving fixture(s) to different (but equal) wireless channels to check for clear space in the radio spectrum from interference by other devices, such as WiFi.

### DIMMING AND/OR CHASE CHANGES ARE JERKY WHEN USING ARIA.

- Check for WiFi sources near to the transmitter or receiver devices. Try changing the transmitter and receiving fixture(s) to different (but equal) wireless channels to check for clear space, from interference by other devices, in the radio spectrum.

## OPTIMIZING SIGNAL STRENGTH VIA CHANNEL SELECTION

Aria™ wireless transceivers use radio frequencies contained within the Industrial Scientific and Medical (ISM) band that runs between 2.4GHz and 2.5GHz. As one of the few license-free radio bands agreed upon in most countries, many other devices also use this band, most notably WiFi. Aria units use the ISM band in a different manner than WiFi and the two can coexist. However, where distances between Aria units are great and WiFi access points are reasonably close, then interference can become an issue. See “Choosing the right location” on page 31.

WiFi uses the IEEE802.11 standard, which divides the ISM band into 13 (sometimes 14) channels, each of which is 22MHz wide. However, the channels overlap and so cannot all be used simultaneously. Hence, most WiFi access points settle upon channels 1, 6 and 11 to avoid any overlap:

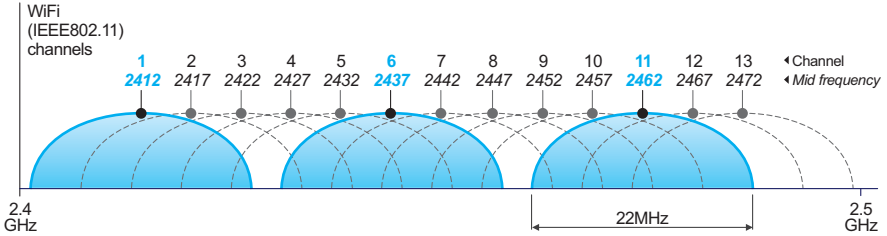

Aria uses the IEEE802.15.4 standard, with channels that are 3MHz in width and not overlapping. Many Aria channels do, however, coincide with the common WiFi channels. The notable exceptions are Aria channels 4, 9 and 14, which fall into the gaps between the most commonly used WiFi channels:

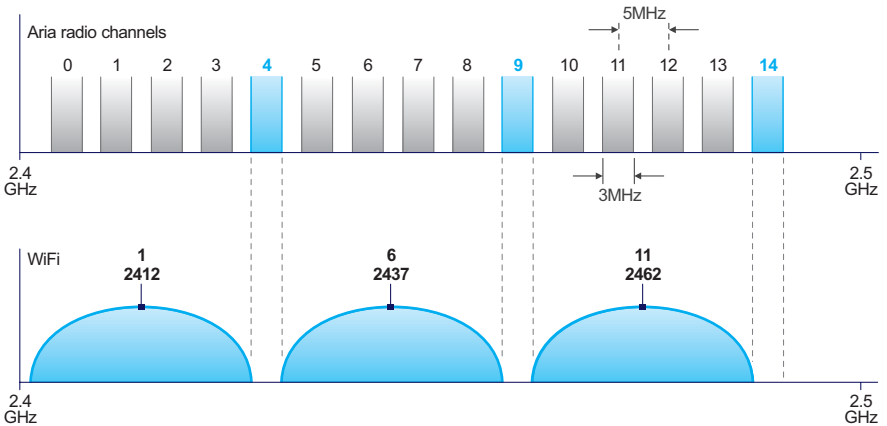

**Before installing Aria wireless devices, such as the Dyna Drum SO, we strongly recommend you carry out a radio spectrum survey to determine any potential sources of temporary or permanent interference issues.**

If you have control over the nearest WiFi access points, it is suggested that you lock them down to one or more of the common channels (to prevent them from roaming) and select radio channels that sit comfortably alongside.

*Note: The Aria channel notations (0 to 14) are directly equivalent to the IEEE802.15.4 channels 11 to 25, inclusive.*



## CHOOSING THE RIGHT LOCATION

Your choice of installation locations for your Aria transmitter(s) and Dyna Drum SO receiver(s) can have a significant effect on their range and speed of communication.

- Avoid installing either the Aria transmitter or the Dyna Drum SO receiver unit(s) near to metallic objects.
- Maintain a clear 'line of sight' path between the Aria transmitter and the Dyna Drum SO.

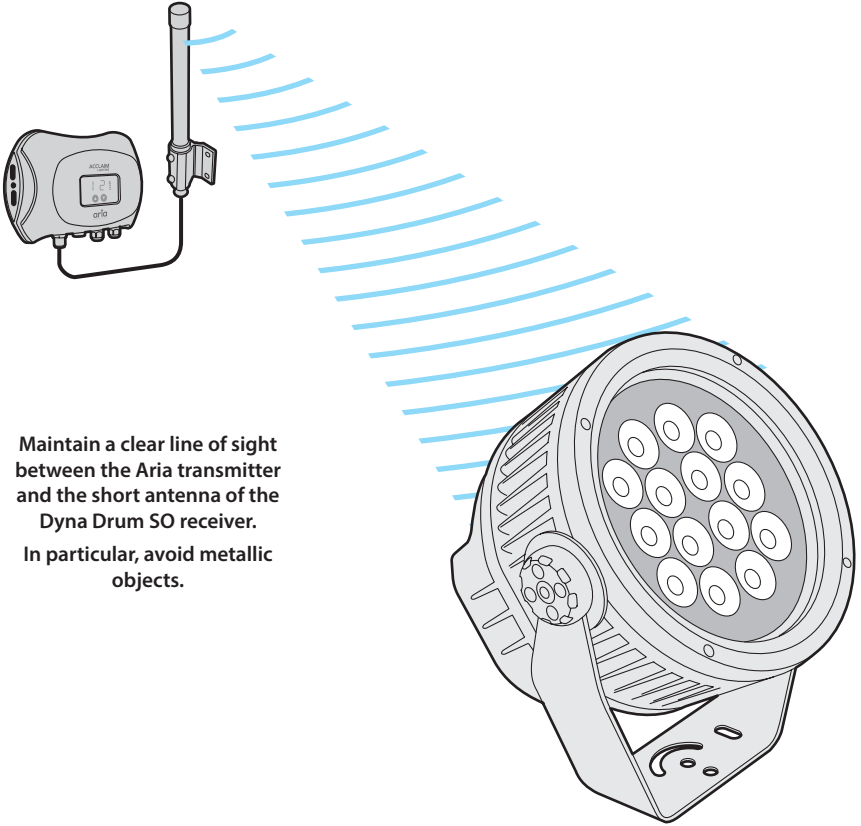

**Maintain a clear line of sight between the Aria transmitter and the short antenna of the Dyna Drum SO receiver.**

**In particular, avoid metallic objects.**

## INTERFERENCE CREATED BY OBJECTS

The composition of nearby objects can have a significant impact on the quality of the RF signal. Here are a few examples:

- Standard drywall does not present much of an issue to the 2.4GHz wireless spectrum. However, things inside or attached to the drywall, such as copper pipe, electrical conduit, and circuit breaker panels, will partially block RF signal propagation.
- Hollow cement block walls will dampen the RF signal.
- Reinforced concrete walls typically contain rebar that will contribute to significant RF signal strength loss.
- Large metal structures such as metal cabinets, HVAC units, machinery, brew kettles, etc. may partially or completely block the RF signal.

## SPECIFICATIONS

Native beam angle	<i>White:</i>	5°
	<i>SCS:</i>	8°
	<i>Color (Quad):</i>	10°
Total lumens	<i>White:</i>	6,787 (4000K model)
	<i>SCS:</i>	3,986 (RGBAW model)
	<i>Color (Quad):</i>	4,350 (QW model)
Lumen maintenance (L <sub>70</sub> )		150,000 hours (25°C)
Housing		Die cast aluminum
Ingress protection		IP66 (wet location)
Impact protection		IK07 (2 joule impact)
Power input		100 - 277VAC 50/60Hz
Power consumption	<i>White:</i>	135W
	<i>SCS:</i>	150W
	<i>Color (Quad):</i>	150W
Operating temperature		-40°F to 125°F (-40°C to 51°C)
Weight	<i>White:</i>	30.6 lbs (13.8kg)
	<i>SCS:</i>	30.6 lbs (13.8kg)
	<i>Color (Quad):</i>	30.6 lbs (13.8kg)

### Certifications



## OLS SPECIFICATIONS

AC conductors	3 x 14AWG
DMX conductors	4 x 20AWG plus shield
Maximum input voltage	305VAC
Surge voltage	1000V
Maximum total line current	15A
Maximum total line power	120VAC: 1,800W
	230VAC: 3,450W
	277VAC: 4,155W
Maximum run length	120VAC: 150' (45m)
	230VAC: 300' (90m)
	277VAC: 350' (106m)
Flame resistance	UL94-V0
IP rating	IP67, wet location
Operating temperature	-40°F to 176°F (-40°C to 80°C)

# DIMENSIONS

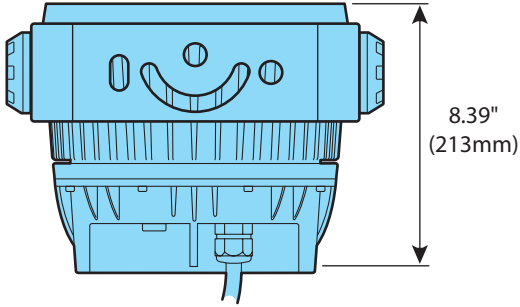
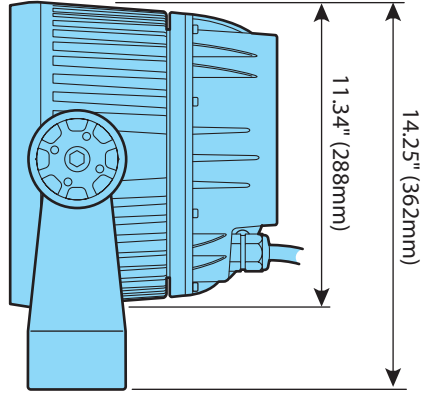
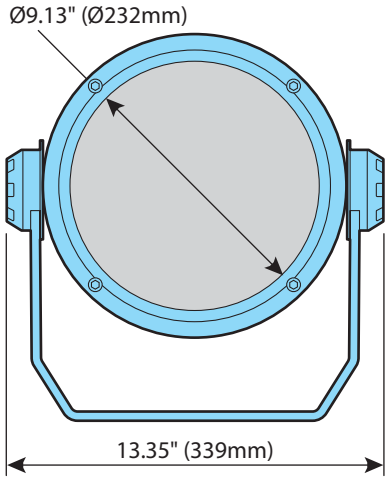

## LIMITED PRODUCT WARRANTY

A. Acclaim Lighting™ hereby warrants, to the original purchaser, Acclaim Lighting finished products to be free of manufacturing defects in material and workmanship for a standard period of:

- Fixtures: 5 Years (1,825 days) from the date of purchase.
- Drivers, power supplies and accessories: 5 Years (1,825 days) from the date of purchase.
- Flex Products: 3 Years (1,095 days) from the date of purchase.
- Controllers: 2 Years (730 days) from the date of purchase.

It is the owner's responsibility to establish the date and place of purchase and warranty terms by acceptable evidence, at the time service is sought.

B. For warranty service, send the product only to the Acclaim factory. All shipping charges must be pre-paid. If the requested repairs or service (including parts replacement) are within the terms of this warranty, Acclaim Lighting will pay return shipping charges only to a designated point within the United States. If the entire instrument is sent, it must be shipped in its original package. No accessories should be shipped with the product. If any accessories are shipped with the product, Acclaim Lighting shall have no liability whatsoever for loss of or damage to any such accessories, nor for the safe return thereof. Acclaim reserves the right to replace the item with same or similar product at its discretion.

C. This warranty is void if the serial number has been altered or removed; if the product is modified in any manner which Acclaim concludes, after inspection, affects the reliability of the product; if the product has been repaired or serviced by anyone other than the Acclaim Lighting factory unless prior written authorization was issued to purchaser by Acclaim Lighting; if the product is damaged because not properly maintained as set forth in the instruction manual.

D. This is not a service contract, and this warranty does not include maintenance, cleaning or periodic check-up nor do we guarantee as part of this warranty any lumen performance during period. Parts not covered by this warranty include: fuses, external power supplies, third party items not manufactures by Acclaim lighting. During the period specified above, Acclaim Lighting will replace defective parts at its expense, and will absorb all expenses for warranty service and repair labor by reason of defects in material or workmanship. The sole responsibility of Acclaim Lighting under this warranty shall be limited to the repair of the product, or replacement thereof, including parts, at the sole discretion of Acclaim Lighting. At no time will installation or re-installation or products labor or liability costs will be assumed by Acclaim Lighting. All products covered by this warranty were manufactured after January 1, 2012, and bear identifying serial number marks to that effect.

E. Acclaim Lighting reserves the right to make changes in design and/or improvements upon its products without any obligation to include these changes in any products theretofore manufactured. No warranty, whether expressed or implied, is given or made with respect to any accessory supplied with products describe above. Except to the extent prohibited by applicable law, all implied warranties made by Acclaim Lighting in connection with this product, including warranties of merchantability or fitness, are limited in duration to the warranty period set forth above. And no warranties, whether expressed or implied, including warranties of merchantability or fitness, shall apply to this product after said period has expired.

F. Marine or extreme weather location applications using Acclaim lighting products are subject to a 2 year limited warranty and Acclaim must be notified prior to delivery of units for such applications so that preventative treatment can be made to the products to ensure proper performance and product life with a special marine code coating / sealing process at an additional cost.

G. The consumer's and or dealer's sole remedy shall be such repair or replacement as is expressly provide above; and under no circumstances shall Acclaim Lighting be liable for any loss or damage, direct or consequential, arising out of the use of, or inability to use, this product. This warranty is the only written warranty applicable to Acclaim Lighting products and supersedes all prior warranties and written descriptions of warranty terms and conditions heretofore published.



[www.acclaimlighting.com](http://www.acclaimlighting.com)